



# Experimental Study on Flexural Behavior of Reinforced Solid and Hollow Concrete Beams

Bibek Pardhe Bhattarai<sup>1</sup> and Niti Bhattarai<sup>1</sup>

<sup>1</sup>UG Scholar, Department of Civil Engineering,  
School of Civil Engineering,  
REVA University, Bangaluru  
India

---

## ABSTRACT

The incessant uptick in the prices of steel reinforcement and cement steer to the dredging up ways to minimize the weight of concrete. This directly reflects on the total outlay for the construction project. In addition to this, anthropogenic CO<sub>2</sub> generated during cement and steel production leads to disturbance to landscape, dust and noise and other significant environmental problems. In reinforced concrete beams, strength of concrete lying in and near neutral axis is not fully utilized and hence this concrete can be supplanted with any light weight material. The idea of providing hollow section to the beam by incorporating PVC pipe in order to reduce the weight of the structure is one of the solutions for light weight beam structure. To check the suitability of such beam structures, an experimental testing was conducted to identify the flexural strength, deflection profile and crack pattern of the solid and hollow beam samples. For this, 6 beams each with dimension (200mm\*300\*2300) mm were taken with 2 beam samples being solid whereas remaining beams with longitudinal circular hollow section below neutral axis at calculated depth. M30 Grade of concrete was used. The beam samples were finally tested under gradually increasing two points loading and Linear Variable Displacement Transducer (LVDT) was used to measure the deflection produced.

**Keywords:** Neutral axis, Hollow reinforced concrete beam, Light-weight material, Self-weight, Flexural behavior, Tension, Compression.

---

## 1. INTRODUCTION

The hegemony of concrete as a material for construction is because of its merits such as low initial and operational costs, workability, resistance to fire, wind, water, rodents etc. Concrete is a composite material in which a binding material (cement or lime) mixed with water on solidification binds the inert particles of well graded fine (such as sand cinder) and coarse aggregates (such as crushed stones, gravel, broken bricks, clinkers etc.) .Monolithic exploration of the natural resources for producing concrete affect to the environmental condition and bring on global warming.. Concrete is used to create hard surfaces which contribute to surface runoff that may cause soil erosion, water pollution and flooding. The concrete industry is one of the largest producers of carbon-dioxide hence it should be used as efficiently as possible. Nowadays new, better and efficient construction methods are being looked at and a slew of theories have been developed to reduce the self weight of the element for a given load carrying capacity.

A beam is a one dimensional horizontal flexural member which resists load by bending and which provides support to slab and vertical walls. In reinforced concrete beams, two zones occur during bending, compression zone at top and tensile zone at bottom. Flexural strength is a material property and is the stress in a material just before it yields in a flexure test. The flexural capacity of the beam is influenced only by the compression stress of the concrete and tensile stress of the steel reinforcement. Concrete on tension side acts as strain transferring media to steel and called as sacrificial concrete, hence complete removal of concrete below neutral is impossible .Hollow core beams with partial removal of concrete on the tension side can be done and PVC pipe can be placed instead hence making beam hollow below the neutral axis.

It is essential to have better bond between PVC pipe and concrete layers at the interface of pipe and concrete and it is to be ensured that no slip occurs between two layers. As the topmost and bottom portion in the beam experience maximum stress and zero at neutral axis, so a cheap and light material such as PVC pipe could be used near the neutral axis. Thus cement can be saved by saving concrete and greenhouse gases emissions can be reduced so that the environment will be less affected.

## 2. LITERATURE SURVEY

**B.S.Karthik, Dr H.Eramma and Madhukaran:** Experimental study was conducted on behavior of concrete with variation of grade in tension and compression zone of RCC beams. They came up with the concept of partial beam thinking that no concrete is required in tension side of simply supported RC beams as concrete in this zone acts as strain transferring media. In order to reduce the cost of construction, grade of concrete is reduced in the tension zone for RCC beams. (1)

[2]**P. Govindan, A.R.Santhakumar** stated that stresses in the beams are maximum at the top and bottom and zero at the neutral axis. So a cheap light material can be used near neutral zone for light weight and economy. It is observed that the load carrying capacity of an in filled beam is about 80-90% of the conventional reinforced concrete beams.

[3]**Patel Rakesh, Dubey S.K., Pathak K.K** studied the behavior of partially utilized concrete of RC beam by replacing it with brick. Brick filled concrete beams act as composite beams. Method of initial function was used for the analysis.

[4]**Yasser, Hermanparung et al** replaced the concrete on tension zone by low compressive strength concrete by mixing them with Styrofoam grains.

[5]**S.Manikandan, S.Dharmar, S.Robertravi:** They conducted experimental study on flexural behavior of reinforced concrete hollow core sandwich beams. RC beams of size 1500\*150\*200mm were casted and tested with and without hollow core in tension zone. To study the flexural behavior, all beams were tested after 28 days curing by applying load at one-third points and performance of hollow core sandwich beams were found similar to that of conventional solid beams.

## 3. OBJECTIVE OF THE PROJECT

The objective is to conduct a study on introducing a new method of supplanting some amount of concrete below NA by creating air voids using PVC pipes without affecting the geometry of the section in order to reduce the weight and cost of RC structures.

## 4. METHODOLOGY

The methodology on the project consists of:

1. Selection of grade of concrete, M30
2. Mix design for M30 concrete
3. Using this mix casting of solid RC beams and partially replaced RC beams
4. Studying the effects of these beams by conducting two point flexural tests.

## 5. MATERIAL TEST

**Table 1: Material Testing Results**

Tests	Materials	Equipment used	Values obtained
Specific gravity	Birla super(OPC 53 grade)	Specific gravity bottle	3.11
Specific gravity	Fine aggregate(M sand)	Pycnometer	2.65
Specific gravity	Coarse aggregate	Wire basket	2.65
Water absorption	Fine aggregate	Vessel	0%
Water absorption	Fine aggregate	Vessel	0.5%
Workability	M30 concrete	Slump cone apparatus	100mm

## 6. MIX DESIGN

For M-30 grade of concrete, concrete mix design was designed as per IS 10262:2009[6].

**Table 2: M30 Mix Proportioning**

Cement(kg/m <sup>3</sup> )	492.5
Fine aggregate(kg/m <sup>3</sup> )	1663.89
Coarse aggregate(kg/m <sup>3</sup> )	1093.92
Water (liters)	197
w/c ratio	0.405
MIX RATIO : 1:1.348:2.22	

## 7. EXPERIMENTAL INVESTIGATION

### A. Experimental Program:

The program consists of casting and testing 6 beams of size( 200\*300\*2000)mm out of which two are singly RC control beams, two are beams with hollow core due to insertion of PVC pipe 40 mm Ø at 160mm from the top and remaining two are beams with hollow core due to insertion of PVC pipe 50mm Ø. Reinforcement for both control beam and hollow beam are 3 bars 16mm Ø at tension zone and 2 hanger bars of 10mm Ø at compression zone. 8mm Ø stirrups at 200mm spacing are provided for both solid and hollow beams as shear reinforcement.

*Depth of neutral axis:* It is calculated by considering M30 grade concrete, Fe500 steel and an effective cover of 25mm. As the concrete reaches failure compression strain, beams fail. If it is balanced or under-reinforced section, steel also reaches its yield strength as concrete fails. However, in over-reinforced beams, steel stress at failure will be below its yield strength.

$$\begin{aligned}(X_u/d)_{\max} &= 0.0035 / [0.0035 + (0.87f_y/E_s) + 0.002] \\ &= 0.0035 / [0.0035 + (0.87 * 500 / 2 * 10^5) + 0.002] \\ &= 0.456\end{aligned}$$

$$X_{u_{\max}} = 126.5 \text{ mm}$$

$$\begin{aligned}\text{And } X_u/d &= (0.87F_y A_{st}) / (0.36f_{ck}bd) \\ &= (0.87 * 500 * 603.186) / (0.36 * 30 * 200 * 275) = 0.44 \\ X_u &= 121 \text{ mm}\end{aligned}$$

Since  $X_u < X_{u_{\lim}}$ , hence it is an under-reinforced section.

$$\text{Moment of resistance: } M_R = 0.36f_{ck}bX_u (d - 0.42X_u) = 0.36 * 30 * 200 * 121 * (275 - 0.42 * 121) = 58.59 \text{ kN-m}$$

$$\text{Again, } M_R = 0.87f_y A_{st} [d - (0.42(0.87f_y A_{st} / (0.36f_{ck}b)))]$$

$$\text{or, } 58.591 * 10^6 = 0.87 * 500 * A_{st} * [275 - (0.42 * (0.87 * 500 * A_{st} / (0.36 * 30 * 200)))]$$

$$A_{st} = 600.818 \text{ mm}^2$$

$$\text{Number of bars} = 600.818 / (\pi * 16^2 / 4) = 2.98 \approx 3 \text{ appx.}$$

The PVC pipe of 40mm Ø and 50 mm Ø is kept at 160mm [8] from the top of concrete surface.

Minimum shear reinforcement  $A_{sv} / (b * S_v) = 0.4 / (0.87 * f_y)$  or,  $S_v = 200 \text{ mm}$ . Hence provide 2 legged 8mm Φ lateral ties @ 200 mm spacing.



Fig.1: Reinforcement cage of control beam



Fig.2: Casting of solid beam



Fig.3: Circular PVC pipe



Fig.4: Casting of hollow beam

### B. Test procedure

100t loading frame was used test the flexural strength of the beams under two point loading. LVDT was used to ascertain the deflection at the centre of the beam. Simply supported conditions were arranged for the specimens and the effective span was 1700mm. Using the hydraulic jack load was applied at the centre of the beam, increased till the beam was just about to collapse, till the ultimate failure. The first crack load and ultimate load were observed with utmost care for each beam. The value of load applied and deflection were noted directly from the control panel of frame and a graph of load vs. deflection, 1<sup>st</sup> crack load of different beams and graph of ultimate load of beams were plotted.

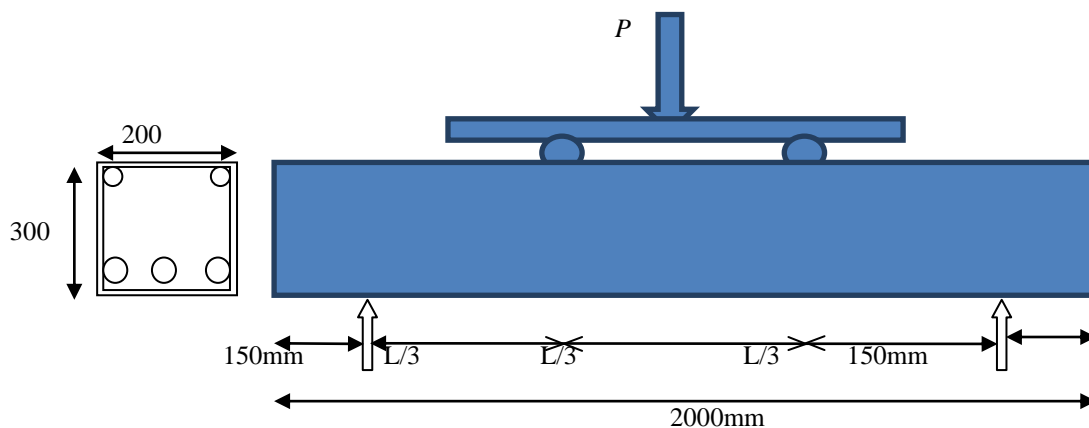

Fig.5: Two Point Loading Setup for Flexural Test

## 8. EXPERIMENTAL RESULTS

### A. Load carrying capacity

The maximum load indicated by LVDT was taken as the ultimate strength of the beams, and the load at which the first crack was seen taken as cracking load. It was found that the load carrying capacity of hollow beam is a bit more than solid beam.

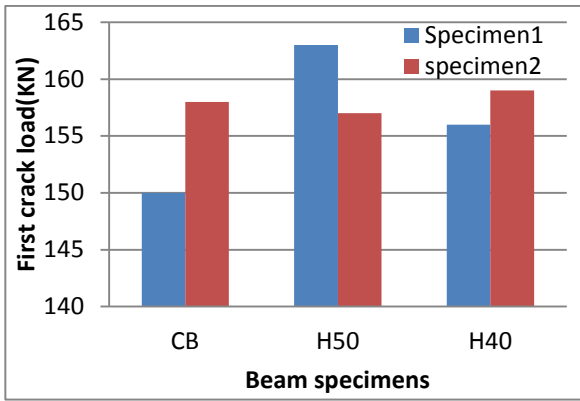

Fig.6: First Crack Load of Beam Specimens

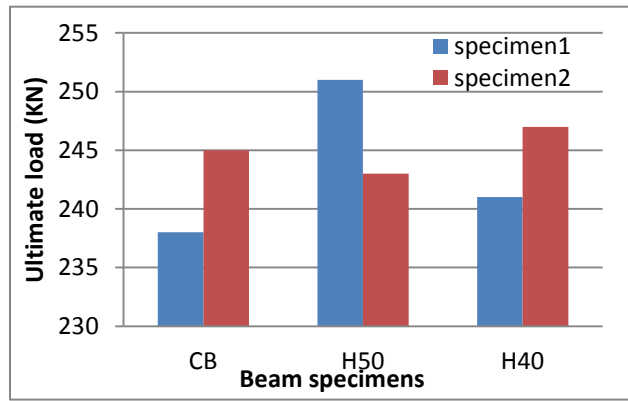

Fig.7: Ultimate Crack Load of Beam specimens

B. Load vs. deflection graph

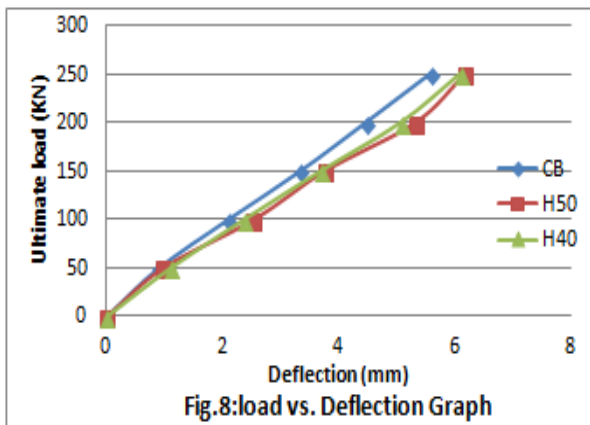

Fig.8:load vs. Deflection Graph

Table 3: Load & Deflection Values

LOAD(KN)	CB(mm)	H50(mm)	H40(mm)
0	0	0	0
10	0.26	0.23	0.12
20	0.45	0.38	0.27
30	0.57	0.52	0.55
40	0.76	0.75	0.86
50	0.9	0.97	1.1
60	1.14	1.14	1.28
70	1.27	1.35	1.58
80	1.57	1.94	1.8
90	1.89	2.17	2.09
100	2.1	2.53	2.37
110	2.29	2.78	2.64
120	2.62	3.04	2.91
130	2.91	3.34	3.14
140	3.08	3.55	3.43
150	3.33	3.75	3.69
160	3.59	4.08	4.01
170	3.83	4.36	4.32
180	4.01	4.5	4.61
190	4.19	4.92	4.79
200	4.46	5.3	5.07
210	4.82	5.6	5.34
220	5.09	5.74	5.62
230	5.35	6.03	5.93
240	5.85	6.16	6.09



The onset of deflection of beam occurs as the load increases. The strength of the beam can be predicted after finding the deflection at corresponding load values. The graph of load vs. deflection is plotted and the load values and corresponding deflection is shown in table. It is found that deflection in hollow beams is a bit more compared to solid beams at all loads up to safe load.

**C. Crack pattern**

It has been found that hollow beams cracked at more loads than the solid beams. Cracks started to appear at about 55-70% of the ultimate load. The difference in loads is very small which shows that concrete just below neutral axis do not significantly increase the cracking load. The reason behind this is due to the fact that concrete near neutral axis experiences almost zero stress. The crack patterns of solid beams and hollow beams can be observed in the figures below.



**Fig.9:Crack Pattern of Solid Beam`**



**Fig.10: Crack Pattern of Hollow (40mm) beam**



**Fig.11: Crack Pattern of Hollow (50mm) beam**

**9. EVALUATION AND DISCUSSION**

**A. Concrete saving and self-weight reduction**

In order to control the cost, it is to be ensured that right quantity of materials is being used with minimum wastage. This can be done by avoiding concrete near neutral axis. With the uptick in the length and depth of the beam, saving of concrete can be done in large proportion.

*CONCRETE SAVING:*

- ❖ Dimension of our beam ; l=200 cm, b=20cm & h=30 cm
- ❖ 5 no. of PVC pipe each of radius= 2.5cm, length = 38.4cm
- ❖ Volume of beam,  $v_1=l*b*h=200*20*30= 120000$  cu.cm
- ❖ Volume of pipe ,  $v_2= 5* \pi r^2 l = 3768$  cu.cm

❖ % reduction in concrete =  $(v_2/v_1)*100$   
 $= (3768/120000)*100 = 3.14\%$

*SELF WEIGHT REDUCTION:*

- ❖ Volume of beam,  $v_1=l*b*h = 2*0.2*0.3 = 0.12$  m<sup>3</sup>
- ❖ Weight of beam ,  $w_1= 2500*0.12 = 300$  kg
- ❖ Volume of PVC pipes = 0.003768 m<sup>3</sup>
- ❖ Hence, weight of concrete saved,  $w_2 = 0.003768*2500 = 9.42$  kg

❖ Weight of hollow beam =  $w_1 - w_2 = 300 - 9.42 = 290.58$  kg

### B. Reduction in labour

Laborers are the cardinal resources in construction fields. As in our study there is total volume saving in concrete, there is reduction in the labor requirement which ultimately decreases the cost of production.

### C. Cost reduction

The cost of production obviously increases as the cost of inputs such as machines, materials, laborers and other overhead expenses increases. From the above study it can be seen that by using reinforced hollow concrete beams, we can ensure saving of significant amount of concrete without bearing any strength loss. Thus, the material cost reduces as the concrete volume decreases which will decrease the labor cost and ultimately the construction cost gets reduced.

### D. Applications

The areas of application of the reinforced hollow concrete beams after the evaluation of results were found to be the fields where abnormal losses in the concrete are minimum. These beams can be used in various fields such as for piers, raft foundations, plinth beams and other similar works.

## 10. CONCLUSIONS

The following conclusions were drawn after conducting the experimental study on hollow RC beams:

1. Behavior of reinforced concrete beams with hollow section below neutral axis is very much similar to that of conventional reinforced concrete beams.
2. Strength of reinforced concrete beams increased by around 6% due to the presence of hollow PVC pipe in place of concrete in the low stressed zone.
3. The selection of circular hollow section proves to be advantageous because curved sections bear more load than any other sections as it avoids sharp corners.
4. It has been observed that the replacement of concrete by hollow pipe in reinforced concrete beams doesn't require any extra labor or time.
5. Self-weight reduction is around 10kg when hollow beams are used. There will be greater reduction in weight when we consider this for a larger section. Thus for sustainable and eco-friendly construction work, hollow reinforced concrete beams can be used as concrete is saved (3.2% reduction in concrete). Thus, emission of carbon-dioxide during the production of cement can be reduced.

## REFERENCES

- [1] B S Karthik, Dr.H.Eramma&Madhukaran (2014) "*Behavior of Concrete Grade Variation in Tension and Compression Zones of RCC Beams*" International Journal of Advanced Technology in Engineering and Science, Volume No.02, Issue No. 07, page 2348 – 7550 330.
- [2] M Siva Prasad, P Satish Reddy, Matta Manoj, N.Guru Murthy, "*Analysis of Sandwich Beam*", International Journal of Science Engineering and Advance, Vol.2, Pp-901-909, 2014
- [3] Rakesh Patel, S.K. Dubey, K.K. Pathak (2014) "*Analysis of infilled beams using method of initial functions and comparison with FEM*" Engineering Science and Technology, an International Journal page- 158-164

[4] Yasser, Herman Parung, Muhammad W. Tjaronge, and Rudy Djamaluddin, “Flexural Characteristics of Reinforced Concrete Beam Using Styrofoam Filled Concrete (SFC) in Tension Zone” IACSIT International Journal of Engineering and Technology, Vol. 7, No. 1, February 2015

[5] S.Manikandan, S.Dharmar, S.Robertravi (2015) “*Experimental Study on Flexural Behaviour of Reinforced Concrete Hollow Core Sandwich Beams*” International Journal of Advance Research In Science And Engineering, IJARSE, page-937, Vol. No.4, Special Issue (01), March 2015 ISSN-2319-8354.

[6] IS 10262: 2009 Concrete Mix Proportion Guidelines (first revision), Bureau of Indian Standards, New Delhi.

[7] IS 456-2000 –“*Plain and Reinforced concrete code of practice*”- Bureau of Indian standards – New Delhi.

[8] Nibin Varghese, Anup Joy, “*Flexural Behaviour of Reinforced Concrete Beam with Hollow Core at Various Depth*”, IJSR 2016