

WIPER CHATTER REDCUTION IN A WINDSHIELD WIPER SYSTEM USING ROBUST DESIGN AND DESIGN OF EXPERIMENTS

¹ANANTHAPADMANABHA S, ¹PRASHANTH B , ¹PRUTHVI R, ¹SANJAY VADIRAJ R S,
Prof. K.S.Mahesh² and Prof. W.Yerriswamy²

¹UG Student, ²Faculty
JSSATE Bangalore

Abstract:

Windscreen wiper or windshield wiper is a device used to remove rain, snow, ice and debris from a windscreen or windshield. Almost all motor vehicles, including cars, trucks, train locomotives, watercraft with a cabin and some aircraft, are equipped with such wipers, which are usually a legal requirement.

A wiper generally consists of a metal arm, pivoting at one end with a long rubber blade attached to the other. The arm is powered by a motor, often an electric motor, although pneumatic power is also used in some vehicles. The blade is swung back and forth over the glass, pushing water or other precipitation from its surface. The speed is normally adjustable, with several continuous speeds and often one or more "intermittent" settings. Most automobiles use two synchronized radial type arms, while many commercial vehicles use one or more pantograph arms.

On some vehicles, a windshield washer system is also used. This system sprays water or an antifreeze window washer fluid at the windshield using several nozzles. The windshield washer system helps to remove dirt or dust from the windshield when it is used in concert with the wiper blades. When antifreeze windshield washer fluid is used, it can help the wipers to remove snow or ice. For winter conditions, some vehicles have additional heaters aimed at the windows or embedded heating wire in the glass. These defroster systems help to keep snow and ice from building up on the windshield. In rare cases, miniature wipers are installed on headlights.

Keywords: Windshield, wipers.

1. INTRODUCTION

1.1Background of the Project Undertaken

Windscreen wiper or windshield wiper is a device used to remove rain, snow, ice and debris from a windscreen or windshield. Almost all motor vehicles, including cars, trucks, train

locomotives, watercraft with a cabin and some aircraft, are equipped with such wipers, which are usually a legal requirement.

A wiper generally consists of a metal arm, pivoting at one end with a long rubber blade attached to the other. The arm is powered by a motor, often an electric motor, although pneumatic power is also used in some vehicles. The blade is swung back and forth over the glass, pushing water or other precipitation from its surface. The speed is normally adjustable, with several continuous speeds and often one or more "intermittent" settings. Most automobiles use two synchronized radial type arms, while many commercial vehicles use one or more pantograph arms.

On some vehicles, a windshield washer system is also used. This system sprays water or an antifreeze window washer fluid at the windshield using several nozzles. The windshield washer system helps to remove dirt or dust from the windshield when it is used in concert with the wiper blades. When antifreeze windshield washer fluid is used, it can help the wipers to remove snow or ice. For winter conditions, some vehicles have additional heaters aimed at the windows or embedded heating wire in the glass. These defroster systems help to keep snow and ice from building up on the windshield. In rare cases, miniature wipers are installed on headlights.

1.2 Working of the present day wiper system on cars

In the present day cars, the working of the wiper is determined by the rate of current flow into a capacitor. When the charge in the capacitor reaches a certain voltage, the capacitor is discharged, activating the wiper motor for one cycle. The motor in the middle converts the circular rotation to an intermittent rotation. The lever arms have different lengths, so the stop position at the reverse point is different.

Intermittent wipers as an option on the company's Mercury line, beginning with the 1969 models.

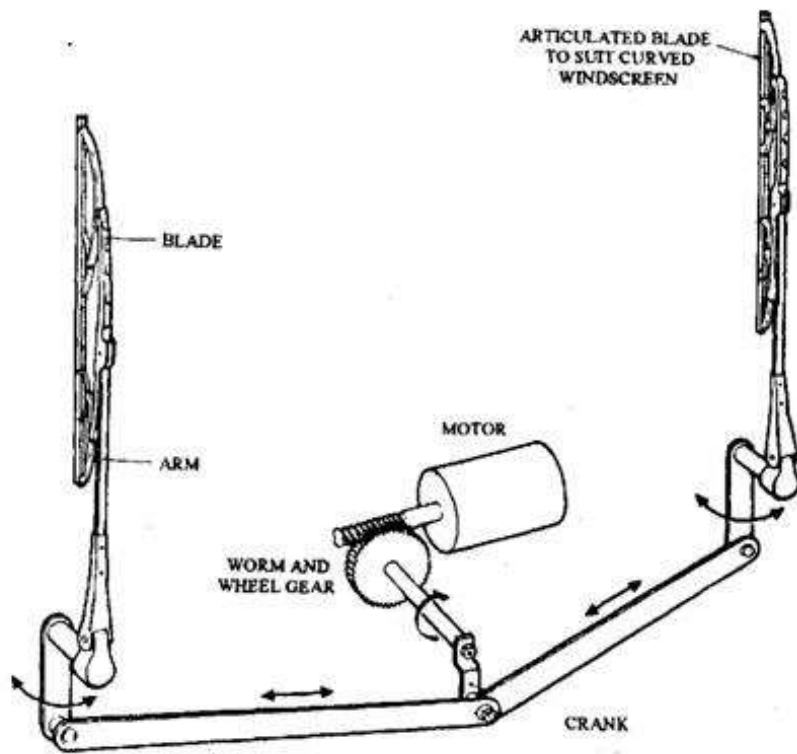
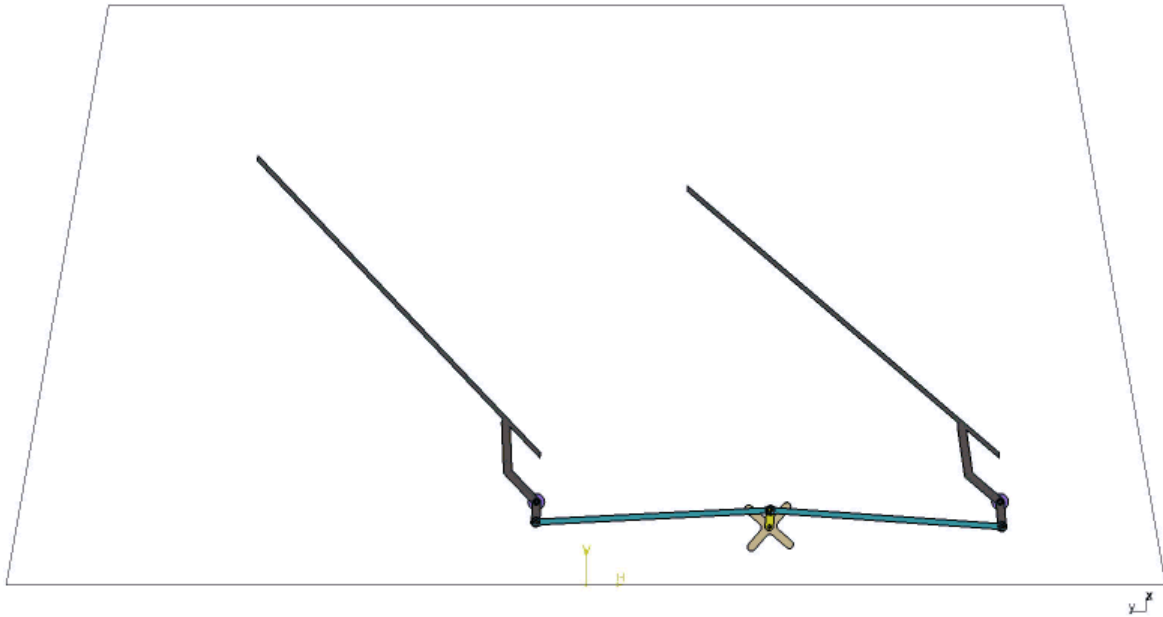

Fig.1.1 Working mechanism of the wiper system .

In March 1970, Citroën introduced rain-sensitive intermittent windscreen wipers on their SM model. When the intermittent function was selected, the wiper would make one swipe. If the

windscreen was relatively dry, the wiper motor drew high current, which set the control circuit timer to delay the next wipe longest. If the motor drew little current, it indicated that the glass was wet, setting the timer to minimize the delay.

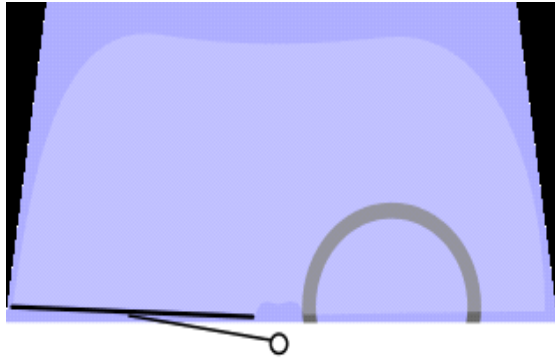

Fig.1.2 Intermittent windscreen wipers.

1.2.1 Pneumatic and hydraulic windscreen wipers

Pneumatic motors drive on a train windscreen wiper. Vehicles with air operated brakes sometimes use [pneumatic](#) wipers, powered by tapping a small amount of pressurized air from the brake system to a small air operated motor mounted on or just above the windscreen. These wipers are activated by opening a valve which allows pressurized air to enter the motor. Early wipers were often driven by a [vacuum motor](#) powered by [manifold vacuum](#). This had the drawback that manifold vacuum varies depending on [throttle](#) position, and is almost non-existent under wide-open throttle, when the wipers would slow down or even stop. This problem was overcome somewhat by using a combined fuel/vacuum booster pump.

- Different types of wiper configuration



Semicircle single-blade system

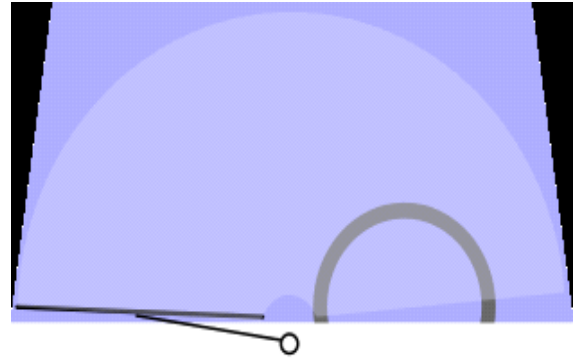

Simple-arc single-blade system

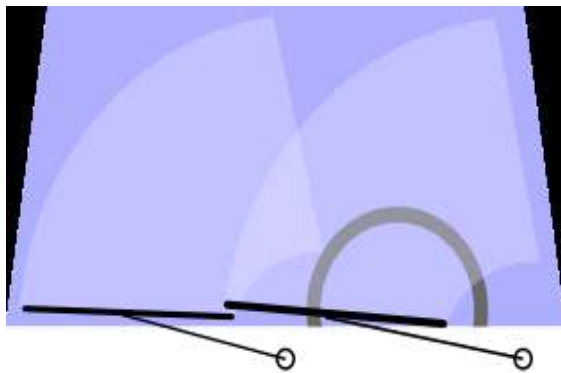

Double arc double blade system

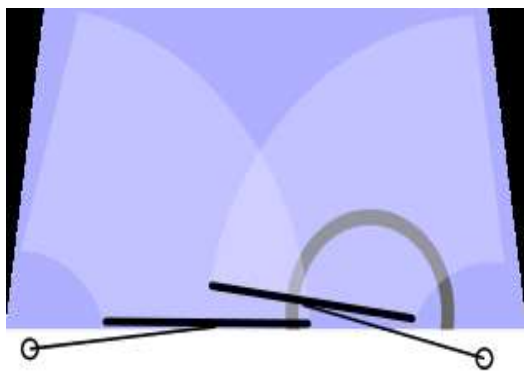

Double blade system with opposite motion

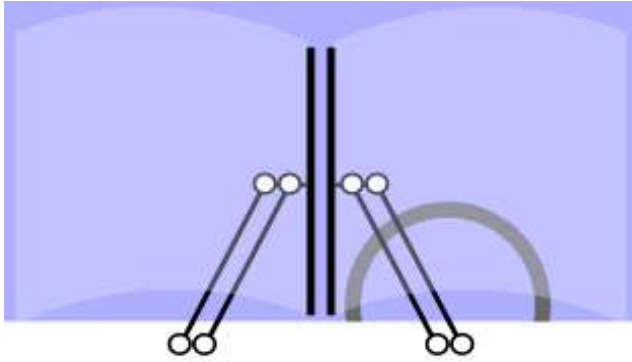

Complex- or eccentric-arc system

1.3. Objectives of the project

As modern passenger cars become increasingly quieter, wiper operation vibration and noise become more noticeable. As a result of the market information analysis, most complaints are about the wiper are concerned with operation noise. Wiper vibration and noise is classified into three main categories namely squeal noise, chattering, and reversal noise. **Squeal noise** is a high-frequency vibration of about 1000 Hz. **Chattering** is the phenomenon that occurs when the wiper blade does not take the proper set and skips across the windshield during operation, potentially causing both acoustic and wipe deterioration which significantly affects the satisfaction of the customers. Chattering noise is a low-frequency vibration of 100Hz or less. **Reversal noise** is an impact sound with a frequency of 500 Hz or less produced when the wiper reverses.

. The major quality concern, which inspired the present robustness study was the wiper chatter phenomenon.

Primary Objective of the project is to reduce the chattering phenomenon using robust design and design of experiments.

2. LITERATURE SURVEY

2.1 Robust design

Robust Design methods, also called the Taguchi Method, pioneered by Dr. Genichi Taguchi, are experimental designs used to exploit the interaction between control and uncontrollable noise variables by robustification -- finding the settings of the control factors that minimize response variation from uncontrollable factors. Control variables are variables of which the experimenter has full control. Noise variables lie on the other side of the spectrum, and while these variables may be easily controlled in an experimental setting, outside of the experimental world they are very hard, if not impossible, to control.

It greatly improves engineering productivity. By consciously considering the noise factors (environmental variation during the product's usage, manufacturing variation, and component deterioration) and the cost of failure in the field, the Robust Design method helps ensure customer satisfaction. Robust Design focuses on improving the fundamental function of the product or process, thus facilitating flexible designs and concurrent engineering. Indeed, it is the most powerful method available to reduce product cost, improve quality, and simultaneously reduce development interval.

2.1.1 Why use robust design method?

Brenda Reichelderfer of ITT Industries reported on their benchmarking survey of many leading companies, "design directly influences more than 70% of the product life cycle cost; companies with high product development effectiveness have earnings three times the average earnings; and revenue growth two times the average revenue growth." She also observed, "40% of product development costs are wasted!"

Robust Design method is central to improving engineering productivity. Pioneered by Dr. Genichi Taguchi after the end of the Second World War, the method has evolved over the last five decades. Many companies around the world have saved hundreds of millions of dollars by using the method in diverse industries: automobiles, xerography, telecommunications, electronics, software, etc.

2.1.2. Robustness Strategy

Variation reduction is universally recognized as a key to reliability and productivity improvement. There are many approaches to reducing the variability, each one having its place in the product development cycle. By addressing variation reduction at a particular stage in a product's life cycle, one can prevent failures in the downstream stages. The Six Sigma approach has made tremendous gains in cost reduction by finding problems that occur in manufacturing or white-collar operations and fixing the immediate causes. The robustness strategy is to prevent problems through optimizing product designs and manufacturing process designs.

The Robustness Strategy uses five primary tools:

1. **P-Diagram** is used to classify the variables associated with the product into noise, control, signal (input), and response (output) factors.
2. **Ideal Function** is used to mathematically specify the ideal form of the signal-response relationship as embodied by the design concept for making the higher-level system work perfectly.
3. **Quadratic Loss Function** (also known as Quality Loss Function) is used to quantify the loss incurred by the user due to deviation from target performance.
4. **Signal-to-Noise Ratio** is used for predicting the field quality through laboratory experiments.
5. **Orthogonal Arrays** are used for gathering dependable information about control factors (design parameters) with a small number of experiments.

2.1.3 P-Diagram

P-Diagram is a must for every development project. It is a way of succinctly defining the development scope. First we identify the signal (input) and response (output) associated with the design concept.

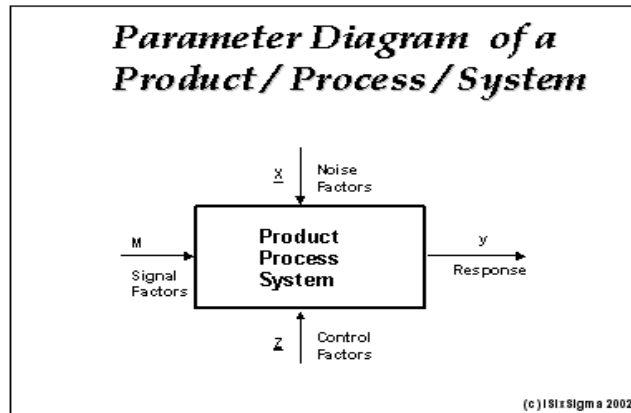

Parameter Diagram of a product, process and system

Next consider the parameters/factors that are beyond the control of the designer. Those factors are called noise factors.. Parameters that can be specified by the designer are called control factors.

The job of the designer is to select appropriate control factors and their settings so that the deviation from the ideal is minimum at a low cost. Such a design is called a **minimum sensitivity design** or a **robust design**. It can be achieved by exploiting non-linearity of the products/systems. The Robust Design method prescribes a systematic procedure for minimizing design sensitivity and it is called Parameter Design.

An overwhelming majority of product failures and the resulting field costs and design iterations come from ignoring noise factors during the early design stages. The noise factors crop up one by one as surprises in the subsequent product delivery stages causing costly failures and band-aids. These problems are avoided in the Robust Design method by subjecting the design ideas to noise factors through parameter design.

2.1.4 Quality Measurement

In quality improvement and design optimization the metric plays a crucial role. Unfortunately, a single metric does not serve all stages of product delivery. It is common to use the fraction of products outside the specified limits as the measure of quality. Though it is a good measure of the loss due to scrap, it miserably fails as a predictor of customer satisfaction. The quality loss function serves that purpose very well.

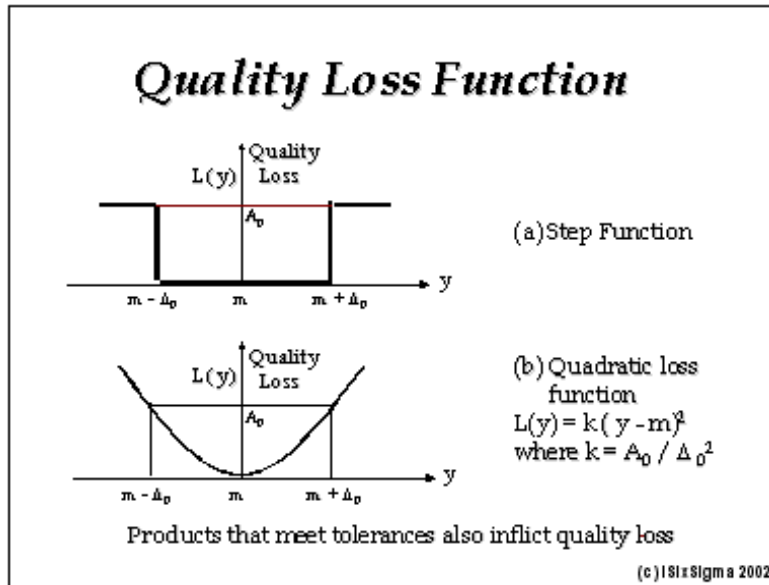

Quality Loss Function

<p>Then the quality loss, L,</p> $L = k * (y - m)^2$ <p>where $k = (A_0 / \Delta_0^2)$</p>	<p>m: target value for a critical product characteristic</p> <p>+/- Δ_0: allowed deviation from the target</p> <p>A_0: loss due to a defective product</p>
---	---

2.1.5 Signal To Noise (S/N) Ratios

The product/process/system design phase involves deciding the best values/levels for the control factors. The signal to noise (S/N) ratio is an ideal metric for that purpose. The equation for average quality loss, Q, says that the customer's average quality loss depends on the deviation of the mean from the target and also on the variance. An important class of design optimization problem requires minimization of the variance while keeping the mean on target.

Between the mean and standard deviation, it is typically easy to adjust the mean on target, but reducing the variance is difficult. Therefore, the designer should minimize the variance first and

then adjust the mean on target. Among the available control factors most of them should be used to reduce variance. Only one or two control factors are adequate for adjusting the mean on target.

The design optimization problem can be solved in two steps:

1. Maximize the S/N ratio, μ , defined as $\mu = 10 \log_{10} (\mu^2 / \sigma^2)$ -this is the step of variance reduction.
2. Adjust the mean on target using a control factor that has no effect on h. Such a factor is called a scaling factor. This is the step of adjusting the mean on target.

One typically looks for one scaling factor to adjust the mean on target during design and another for adjusting the mean to compensate for process variation during manufacturing.

2.1.6 Static Versus Dynamic S/N Ratios

In some engineering problems, the signal factor is absent or it takes a fixed value. These problems are called Static problems and the corresponding S/N ratios are called static S/N ratios. In other problems, the signal and response must follow a function called the ideal function. the response and signal (set point) must follow a linear relationship. Such problems are called dynamic problems and the corresponding S/N ratios are called dynamic S/N ratios.

2.2 DOE++: Software Tool for Experiment Design and Analysis (DOE)

ReliaSoft's DOE++ software tool facilitates traditional Design of Experiments (DOE) techniques for studying the factors that may affect a product or process in order to identify significant factors and optimize designs. The software also expands upon standard methods to provide the proper analysis treatment for interval and right censored data — offering a major breakthrough for reliability-related analyses.

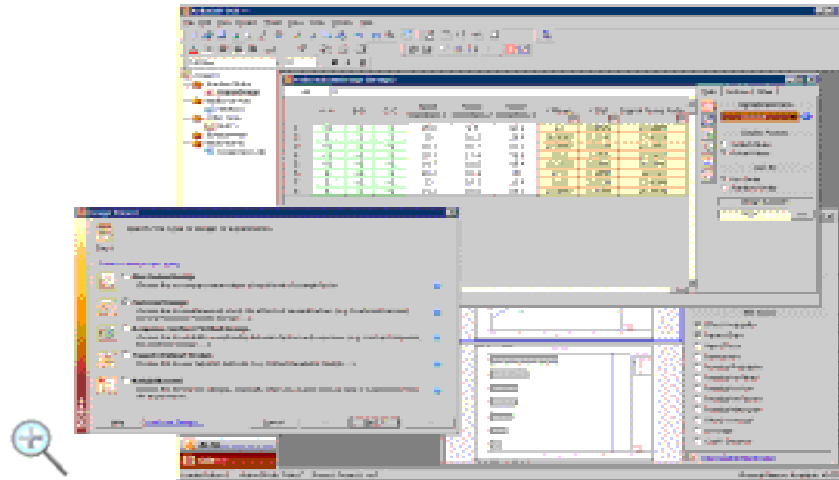

DOE++ Software Screen Shot

2.2.1 Software Features

DOE++ guides you through the designs and analyses, necessary for all phases of the experiment design and analysis strategy (DOE strategy), from screening for significant factors, through in-depth analysis of the targeted factors and factorial interactions, to selecting input levels for optimal performance. The software supports a variety of experiment design types, including factorial designs, fractional factorial designs, Taguchi robust designs, response surface method designs and reliability DOE.

2.2 2 Applications and Benefits

The DOE++ software provides an extensive array of tools to help you design experiments that are effective for studying the factors that may affect a product or process and analyze the results of such experiments. Some of the many useful applications include the ability to:

- Identify the significant factors that affect a product or process.
- Evaluate ways to improve and optimize the design.

2.3 Patents on wiper mechanism

2.3.1 Anderson's 1903 window cleaner design

American inventor Mary Anderson is popularly credited with devising the first operational windshield wiper in 1903. In Anderson's patent, she called her invention a "window cleaning device" for electric cars and other vehicles. Operated via a lever from inside a vehicle, her version of windshield wipers closely resembles the windshield wiper found on many early car

models. Anderson had a model of her design manufactured, then filed a patent (US 743,801) on June 18, 1903 that was issued to her by the US Patent Office on November 10, 1903.

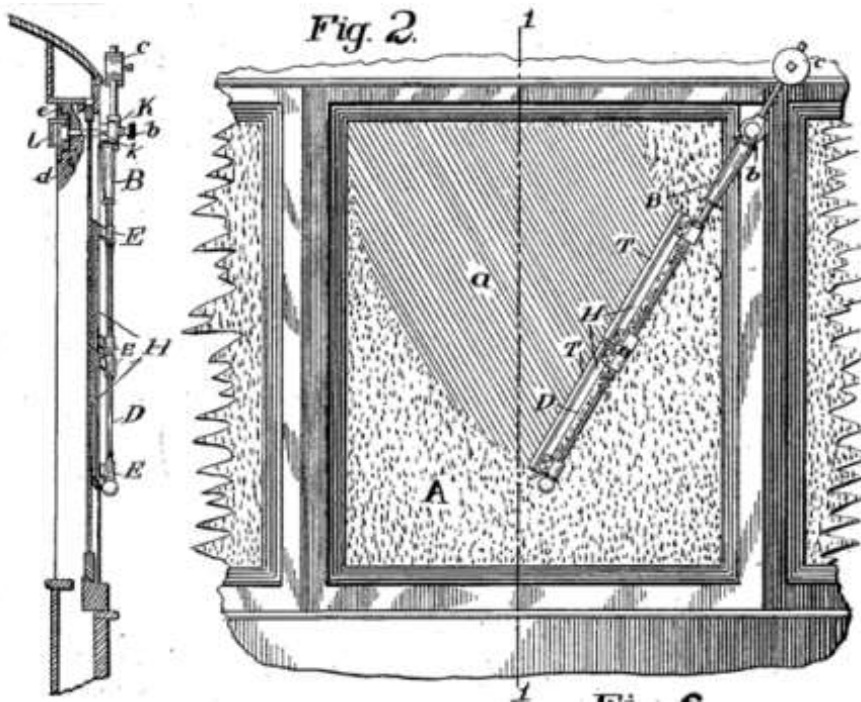

Fig.2.4 Anderson's 1903 window cleaner design

2.3.2 Douglass's 1903 locomotive cab window cleaner

A similar device is recorded 3 months prior to Anderson's patent, with Robert A Douglass filing a patent for a "locomotive-cab-window cleaner" on 12 March 1903.

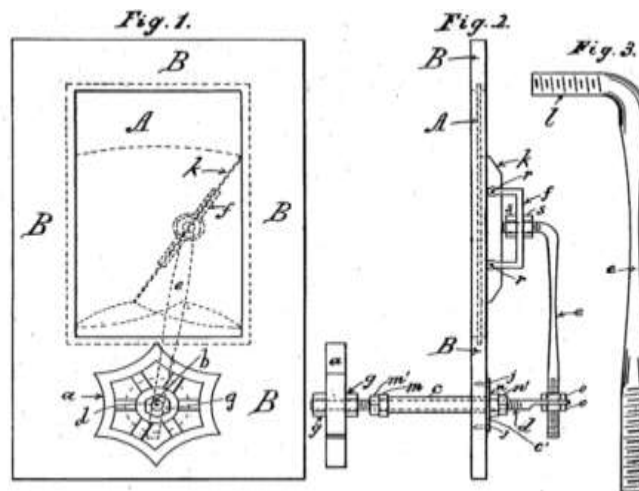

Fig.2.5 Douglass's 1903 locomotive cab window cleaner

3. Literature Survey

Mr. Anil G. Bansode et al., in their paper upgrade the older cars system by providing automatic Wiping system, to improve the system by using sensor with actuator and to design a basic program that will fully operate with the system.

The concept of this proposed wiper system is similar with other existing conventional wiper. N. M. Z. Hashime al., in their study pointed out that driver's constant attention in adjusting the wiper speed and the intermittent wiper interval because the amount of precipitation on the windshield constantly varies according to time and vehicle's speed. The manual adjustment of the wiper distracts driver's attention, which may be a direct cause of traffic accidents. So in their paper they proposed automatic windshield wiper system, based on intensity of rain.

I M Awang et al., analyzed different kind of sounds in the wiper mechanism by modeling the wiper in finite element analysis .Complex Eigen value analysis was carried in ABAQUS to determine stability of the wiper blade assembly. It was found that the frequencies in two different speeds are almost identical. This suggests that the rotational speed of the wiper may not influence the noise generated in the wiper system

3.1 Problem definition

Occurrence of chatter phenomenon in windshield wiper system causing acoustic problems and wipe deterioration ultimately resulting in decreased customer satisfaction.

Wiper arm/blade forms an integral part of the windshield system. Chatter is the phenomenon that occurs when the wiper blade does not take the proper set and skips across the windshield during operation, potentially causing both acoustic and wipe deterioration which significantly affects the satisfaction of the customers. The major quality concern, which inspired the present robustness study was the wiper chatter phenomenon

3.2 Methodology

Instead of measuring wiper quality deterioration, a robust design approach will be used by evaluating the actual time that a blade takes to reach a fixed point on the windshield at a given cycle. This means that the focus will be on measuring the functionality of the system and not the end characteristics.

The ideal function for this study is based on the following hypothesis for an ideal system: The actual time for the wiper blades to reach a fixed point on the wind shield during a cycle should be the same as theoretical time (ideal time) for which the system was designed. However, under the presence of the noise factors, the actual time will differ from the theoretical time. Furthermore, the actual time of a robust system under varying noise conditions should have less variation and be closer to the theoretical time.

In general, due to the noise effects, the actual time would be always longer than the theoretical time determined by the design i.e. $\beta > 1$. $\beta = 1$ would be the ideal case.

A special test fixture is built for this purpose, and three sensors are attached to the windshield to record a signal when the wiper blade passes them. The strain gauges will pick up and record, the lateral and normal loads to the wiper arm.

Three design configurations will be tested and the noise factors will be grouped into two noise factors each with levels

Table-3.1 Control factor levels

Factors	Level-1	Level-2	Level-3
Arm lateral rigidity	Design 1	Design 2	Design 3
Super structure rigidity	Median	High	Low
Vertebra shape	Straight	Concave	Convex
Spring force	Low	High	--
Profile Geometry	Geometry1	Geometry2	Geometry 3
Rubber material	Material 1	Material 2	Material 3
Graphite	Current	High graphite	None
Chlorination	Median	High	Low
Attach method	Clip	---	Twin screw

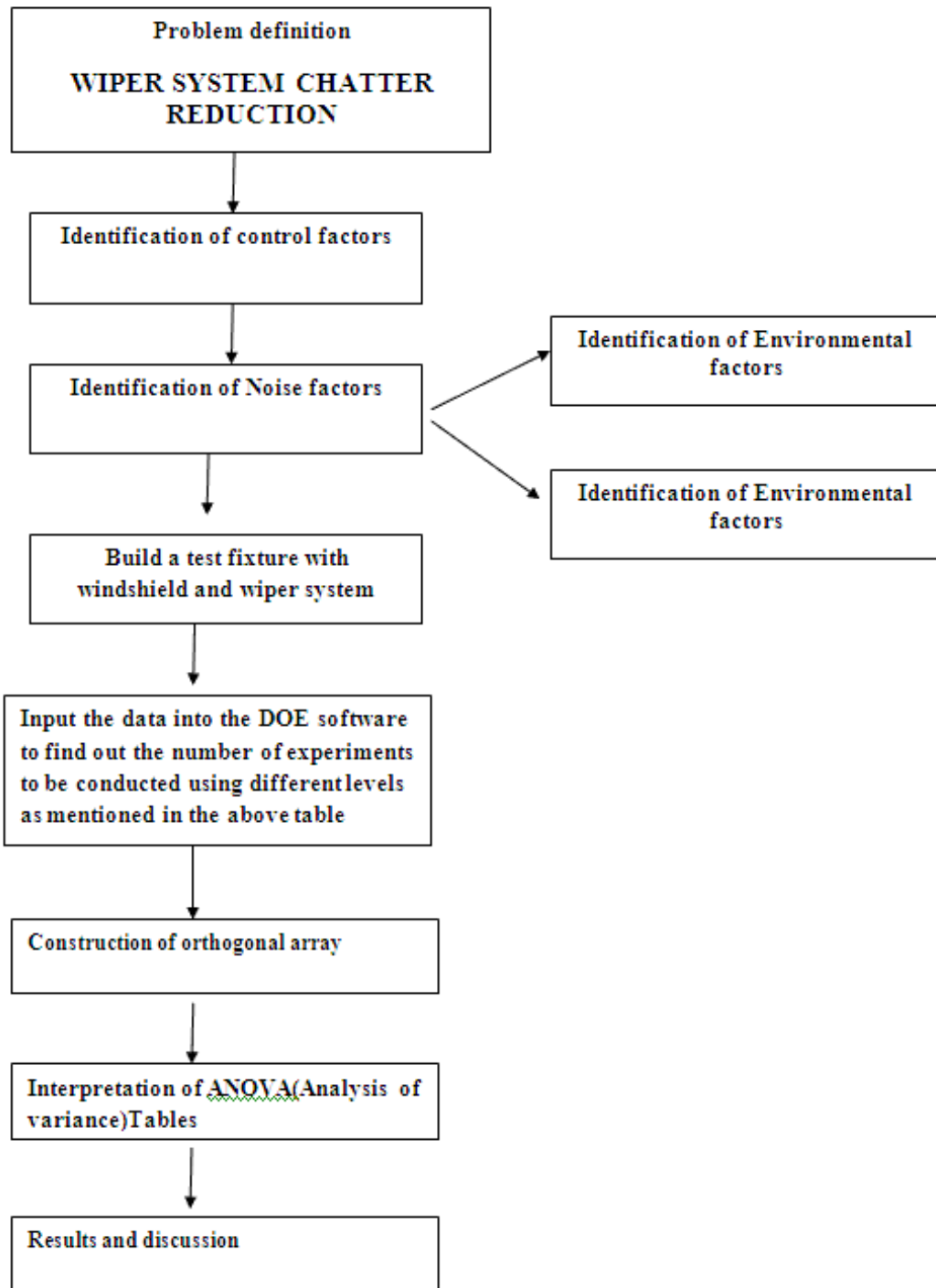

Fig.2.6 Flow chart

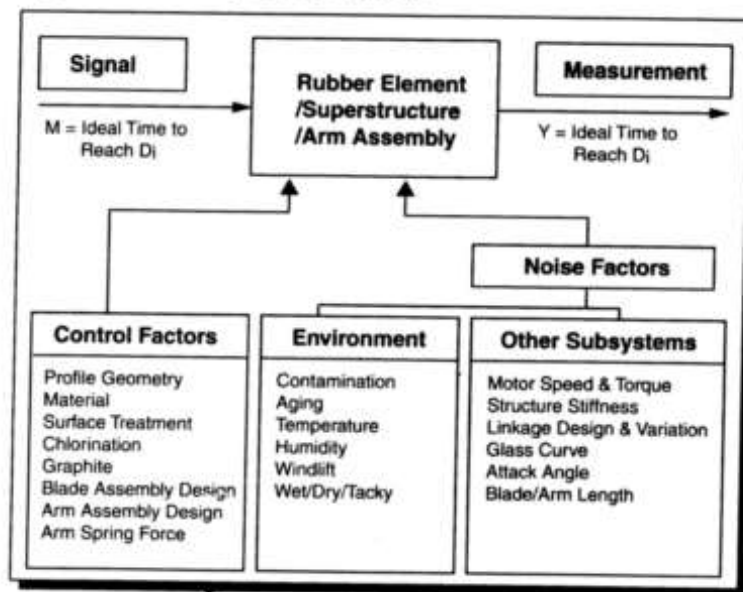

Fig.2.7 System architecture of the wiper system

4. EXPECTED RESULTS

This robust design study for the wind shield wiper system will indicate that:

- 1) The control factors, chlorination, graphite, arm rigidity and super structure have significant impacts to the optimal wiper system.
- 2) Load distribution on the blade has minimal influence.
- 3) Low friction and high rigidity of the wiper arm and blade will lead to reduction of chatter in the windshield wiper system and forms a robust design.
- 4) Identification of an optimal design that can help minimize the chatter phenomenon.

REFERENCES

1. (2016) , How Windshield Wipers Work
2. S. Goto, H. Takashi, T. Oya, Clarification of Mechanism of Wiper Blade Rubber Squeal Noise Generation, JSAE Review 22 (2001), 57- 62.
3. J. Lévine, On the Synchronization of a Pair of Independent Windshield Wipers, IEEE, Transactions on Control Systems Technology, Vol. 12 No. 5 (2004).

4. S. Okura, T. Sekiguchi, T. Oya, Dynamic Analysis of Blade Reversal Behavior in a Windshield Wiper System, SAE Technical Paper, 2000-01-0127.
5. S. Okura, T. Oya, Complete 3D Dynamic Analysis of Blade Reversal Behavior in a Windshield Wiper System, SAE Technical Paper, 2003-01-1373
6. Juran, J. M. Quality Control Handbook. New York: McGraw Hill Book Co., 1979.
7. Sullivan, L. P. "Reducing Variability: A New Approach to Quality." Quality Progress, (July 1984) pp. 15-21.
8. Hicks, C. R. Fundamental Concepts in the Design of Experiments. New York: Holt, Rinehart and Winston, 1973
9. Taguchi G. and Wu, Yu-In. Introduction to Off-Line Quality Control. Central Japan Quality Control Association. Meieki Nakamura-Ku Magaya, Japan, 1979..
10. Taguchi, G. and Phadke, M. S. "Quality Engineering through Design Optimization." Conference Record, GLOBECOM 84 Meeting, IEEE Communications Society. Atlanta, GA (November 1984) pp. 11064113.
11. US Patent Office on November 10, 1903, patent no US 743,801
12. US Patent Office on 12 March 1903
13. N. M. Z. Hashim, S. H. Husin, A. S. Ja'afar, N. A. A. Hamid, Smart Wiper Control System Faculty of Electronics & Computer Engineering, Universiti Teknikal Malaysia Melaka, Hang Tuah Jaya Durian Tunggal, Melaka Malaysia *International Journal of Application or Innovation in Engineering & Management (IJAIEEM)*.
14. Mr. Anil G. Bansode, Prof.S.O.Rajankar and Dr.M.G.Ghatule, Design and development of smart automatic windshield wiper system: fuzzy logic approach, *International Journal of Engineering and Science ISSN: 2278-4721, Vol. 1, Issue 1 (Aug2012), PP 14-20*.
15. I M Awang, C Y Leong, A R Abu-Bakar, B Abd-Ghani, R Abd-Rahman, and M Z Md-Zain ,Modeling and simulation of automotive wiper Noise and vibration.