



# Development of Radio Waves Based Mobile Phone Charger

Amani Emmanuel <sup>1</sup> and Nabahani Bakari <sup>2</sup>

<sup>1</sup>Undergraduate and <sup>2</sup>Assistant Lecturer

Department of Information and communication Technology

Mbeya University of Science and technology

Mbeya, Tanzania

---

## ABSTRACT

*The issue of charging our mobile phone is very paramount to mobile phone users especially to those who use smartphones. Therefore, there is a need for improving the service or means for charging our mobile phone to a maximum efficiency as possible, and this is possible by coming up or designing a mobile phone charger which will at least minimize the current challenges of mobile phone users regarding with charging their phones so that they will enjoy the use of their mobile phones.*

*Development of mobile phone charger using radio waves helps mobile phones user to have an efficient way of charging their mobile phone by simply having this type of charger which utilizes free radio waves available to charge their mobile phones. Under this project, the study will concentrate on capturing the radio waves from different sources and convert those radio waves to direct current (D.C) so as to charge a phone.*

**Key words:** Radio waves, Mobile phone charger, Antenna, Dc voltage.

---

## List of Abbreviations

MUST - Mbeya University of Science and technology

RFID - Radio Frequency Identification

LED – Light Emitting Diode

AC – Alternating current

DC – Direct current

IC – Integrated Circuit

JASP – Jeffrey's Amazing Statistics Program

WPT - Wireless Personal Terminal

PAPR - Peak-to-Average Power Ratio

## 1.0 INTRODUCTION

### 1.1 Situation analysis

Cellular telephone technology became commercially available in the 1980's. Since then, it has been like a snowball rolling down hill, ever increasing in the number of users and the speed at which the technology advances. When the cellular phone was first implemented, it was enormous in size by today's standards. This reason is two-fold, the battery had to be large and the circuits themselves were large. The circuits of that time used in electronic devices were made from off the shelf integrated circuits (IC), meaning that usually every part of the circuit had its own package. These packages were also very large. These large circuit boards required large amounts of power which meant bigger batteries. This reliance on power was a major contributor to the reason these

phones were so big. Through years' technology has allowed the cellular phone to shrink not only the size of the ICs but also the batteries. New combinations of materials have made possible the ability to produce batteries that not only are smaller and last longer but also can be recharged easily. However, as technology has advanced and made our phones smaller and easier to use we still have one of the original problems we must plug the phone into the wall sockets from main grid electrical supply of the nation in order to recharge the battery. Most people accept this as something that will never change so they might as well accept it and carry around either extra battery [1].

## 1.2 Problem Statement

Charging our mobile phones is a real big challenge that we face whenever we are in remote areas, places with limited number of wall sockets as well as availability of our normal electricity supply. Try to think on power sustainability of our mobile phones batteries is not sufficient to cover the needs so we are always supposed to plug our mobile phone charger on a wall socket so as to charge phone batteries which is associated with complication electric supply availability and wall sockets of which is the challenge we face. Considering the fact that almost everyone has a mobile phone now days especially the youth, most of them use smart phones for their daily business be it for personal issue or for the company he or she is working for. Smart phone came up with a lot of application that are necessary to run our daily activities so is the power consumption of those applications leaving us with no options but to charge our phones whenever it is required after the charge store which is the battery has gone down or finished.

Mobile consumer of electronics devices, especially phones are powered from batteries which are limited in size and therefore capacity. This implies that managing energy well is paramount in such devices. Good energy management requires a good understanding of where and how the energy is used. To this end we present a detailed analysis of the power consumption of a recent mobile phone. [2]

The focus of this project is to come up with the charger that will not be depending from such factors as supply from the national grid, the need of wall sockets availability, challenges related to power cut from the supply and others, this is only possible by having an alternative means to produce the energy for charging our mobile phone from the available resources and actually per this project we referring to free radio waves available to our surroundings by simply capturing them and converting to direct current so as to charge mobile phones' batteries.

## 2. LITERATURE REVIEW

In this project of designing a mobile phone charger that utilizes free radio waves available in our surroundings from different sources such as radio signals and wireless transmission such as WI-FI which are then captured using an antenna and converted to a dc using the special circuitry and later amplified the small obtained amount of voltage (signal) to a required amount for charging a mobile phone through some amplification stages. This project proposal is based on a very simple concept whereby we need to have a means for capturing all the radio waves available in our surroundings and utilize them to solve the presented problem above, meaning using them to charge our mobile phones by converting them into direct current (D.C). Scientist laws of energy conservation and theories have proven that *energy* cannot be created or destroyed, but only changed from one form into another or transferred from one object to another. [3]

As a precursor to this project there have been many projects involving charge pumps. These projects range from tuning the charge pump to using results from existing charge pumps to drive other circuits. For the tuning projects, usually the testing is done using a light emitting diode (LED). RF energy is transmitted to the circuit and the charge pump stores the energy in a large capacitor. When the amount of charge is large enough, the LED uses the stored energy to light for a moment. This is called a charge-and-fire system. In other research, charge pumps were tested from earlier projects that were used to power other circuits. This type of technology is very useful in Radio Frequency Identification (RFID) applications. The way RFID systems work is that when a chip passes through a scanner device, power is sent to the chip from the scanner. In older systems, the frequency or amplitude of this signal was modulated by the chip and sent back. This technique is called backscatter. But, in more recent systems, the chips are getting more complicated and require much more power to run. The RFID system is unsuitable for batteries mostly because they have to be small, but also because the batteries will eventually die and require changing. But, with a good antenna, a charge pump should be able to handle the powering of these circuits and never will need to be serviced. Because the circuits are small, the power required is minimal. The power Charge pump refers to nothing but the circuit that, when given an input A.C signal it outputs D.C voltage larger than simple rectifier would generate. It can be thought as A.C to D.C converter that both rectifies A.C and elevates D.C level, it is the foundation of many power converters used in electronic devices this is according to thesis written by Harrist. [4]

In the research of the wireless charging of mobile phones using microwave, main motive is shown to make the recharging of mobile devices wherever we want without charger this is done only when there is a use of microwave, the microwave signal transmitted from transmitter via special kind of antennas called slotted wave guide antennas at a frequency of 2.45GHZ. We have to add a sensor and rectenna circuit in our mobile phone to do this task successfully. This technology was too expensive to be implemented and the frequency of 2.45GHZ was considered to be harmful for male reproductive system. [5]

Wireless power transmission holds a promise able future for generating a small amount of electrical power for charging mobile phones wirelessly. Growing Importance in wireless field which has numerous benefits such as it would completely eliminate the need of carrying charger along with mobiles, no more need of keeping mobiles nearer to the socket as cables have shorter length than area covered by wireless field. Paper presents architecture of wireless transmission for mobile systems (WPTM), design specifications with simulation of quarter wave printed monopole antenna which is best suitable for the project because of its high gain and efficiency and low loss. The technology and theory behind wireless charging exist around for a long time, the idea was initially suggested by Nikola Tesla who demonstrated the principle of wireless charging at the turn of the century. This paper implies wireless transmission of power using RF waves. A suitable charging circuitry is demonstrated which can capture high frequency signal and convert it into DC signal. [6]

Mobile phones Nowadays, they are our constant companions our confidants. They know everything about our everyday lives. Every day, whether we are on our way to or from work or just wandering around the city, mobile phones collect this information. We take photos, share our impressions on social networks, send work and non-work related mails, text messages, and make calls. [7] Considering the functionality of our mobile phones applications so is the power consumption because these application operations requires more energy making our phone batteries not to last longer and because most of us we are using wired mobile phone charger we need wall sockets whenever in need for charging our phones of which is not easy.

As a consequence, wireless power transfer and energy scavenging techniques are becoming of paramount importance. More than ever, energy harvesters with good performance are being developed in order to harness energy from different sources. Even new materials and compact solutions are being investigated in order to fit the different environments and applications (wearable sensors, portable devices, and so forth).

Many of these existing projects described under this literature review are weak in such a way that cannot be friendly in remote areas and also, they rely on availability of power from the national grid supply.

### **2.1 Project Significance**

A number of project proposal have been conducted in relation to the design of electronics devices in different countries, where Tanzania is not an exception. However, only few studies have been conducted in Tanzania and have not attempted to make a comparison of electronics devices including the design of mobile phone chargers. The proposed project is expected to cover the limitations such as availability of our normal power supply from the national grid as well as remote area coverage. This project will bring a new change to the society so that there will no more complications related to charging our mobile phones.

## **3.0 PROJECT OBJECTIVE**

### **3.1 Main Objective**

The main objective of this proposed project is to develop a mobile phone charger that is utilizing radio waves to charge mobile phone.

### **3.2 Specific Objectives**

- i. To connect and assemble components for conversion circuitry
- ii. To connect an antenna for capturing radio waves
- iii. To amplify the output dc through some stages
- iv. To integrate the circuit with a phone charging terminal
- v. To simulate the designed circuit
- vi. To develop a prototype
- vii. To test the prototype

### 3.3 Scope and Limitation of the project

Tanzania has many graduates who have been making a number of studies related to the science of electronics. This project proposal narrowed down to cover only mobile phone users especially those who use smart phones because they are the ones who face the challenge of power sustainability of the batteries of their mobile phones. Furthermore, the project proposal will also consider those individuals who are not using smart phones so as to later draw a good relationship of the statistics between the two

## 4. METHODOLOGY

### 4.1 Data Analysis and System design

The aim of design of any kind of a system is to make sure that, the system is explained in terms of its behavior, structure and interaction with external entities. The modern approach chosen to explain the interaction and behavior of my system / project.

The modern way of designing was used and the following diagrams were modelled using Unified Modelling Language (UML).

- i. Block diagram
- ii. Use case diagram
- iii. Sequence diagram
- iv. Class diagram

Block diagram of the project

This is a graphical language explaining about the structure of the system from the input to the output as well as th functions of the particular system.

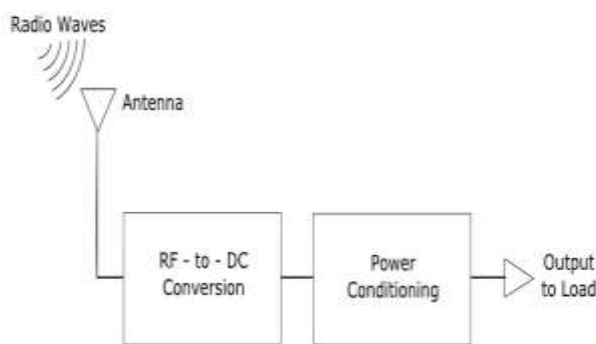

Figure 1: block diagram

Use case

These kinds of diagram explain about the interaction of my system with some of the external entities that are part of my system, explaining how they communicate.

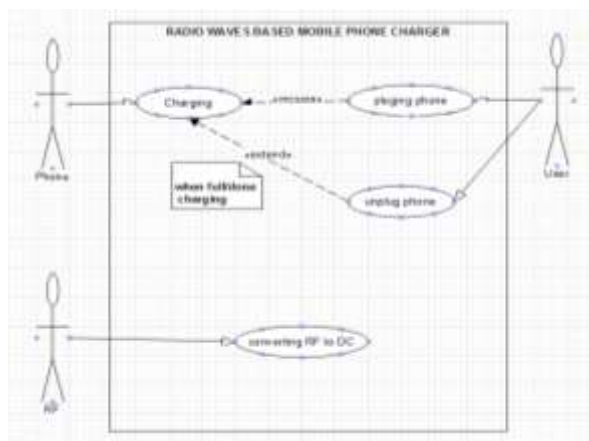

Figure 2: Use case diagram

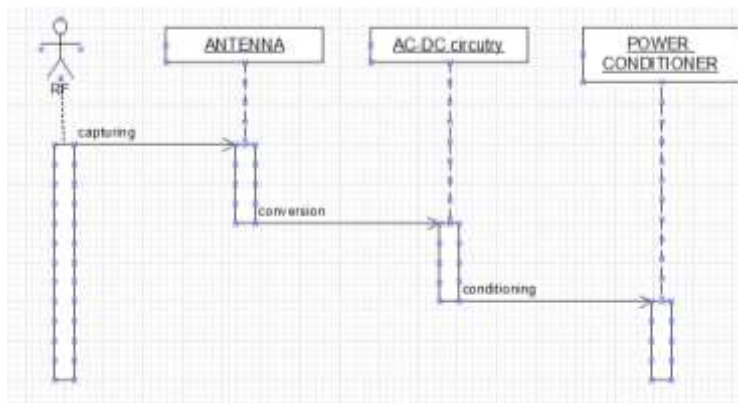

Figure 3: sequence diagram

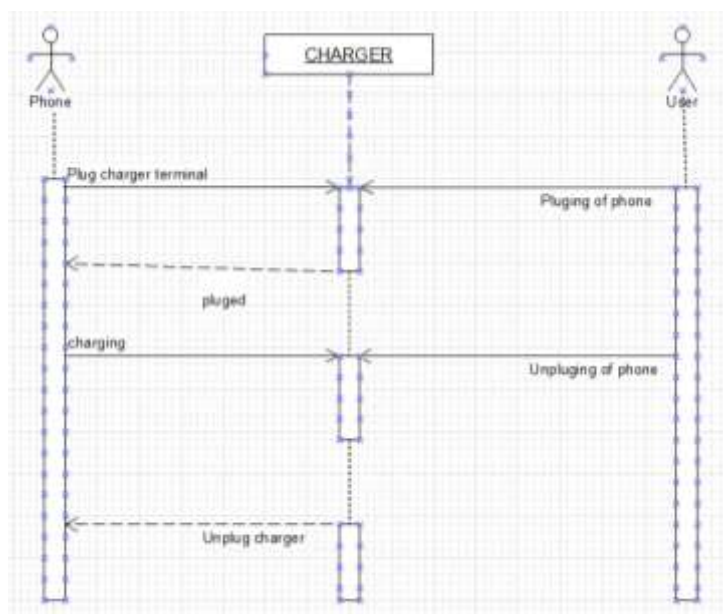

Figure 4: sequence diagram

**4.2 The prototype designing**

The prototype is fabricated on a PCB board which consists of the shaping of an adhesive copper tape by standard photolithography and the application of the Cu pattern on the hosting substrate by means of a sacrificial layer. In the present case the top and the bottom side have been separately tackled and then aligned on the two sides of the same substrate. The final prototype features a weight of just 1.5 grams. Since the rectenna is fabricated on a flexible substrate, it is susceptible to be bended (intentionally or not). To this purpose, a study of the impact of the bending over the antenna radiation performance has been carried out via electromagnetic simulation. It highlights that for a small bending (radius of curvature higher than 70 mm) the antenna performance is substantially unchanged. Moreover, the estimated reduction of the maximum antenna gain is lower than 1 dB. Finally, the output DC voltage and efficiency are presented as a function of frequency, in order to check the rectenna performance even outside the design band. In this case the transmitted power has been kept fixed to 10 dBm and the measurements have been recorded for two different transmitter-to-rectenna distances (20 and 30 cm). It is worth noticing that also in this case the efficiency is calculated by considering the measured RF input power captured by the standalone antenna. On the other hand, the power density (S) is calculated dividing the measured RF input power by the effective area of the antenna, estimated with the well-known equation.

$$A_{eff} = G \frac{\lambda^2}{4\pi}$$

The components used for the prototype build up where as listed below:

- i. Antenna(wire)
- ii. 0.22pF ceramic capacitors 100V
- iii. Shortky diodes (1N4148, OA70 and 1N34A)
- iv. Electrolytic capacitors 16V 100uF
- v. Phone charging terminal.

The circuit design and Simulation using NI Multism software.

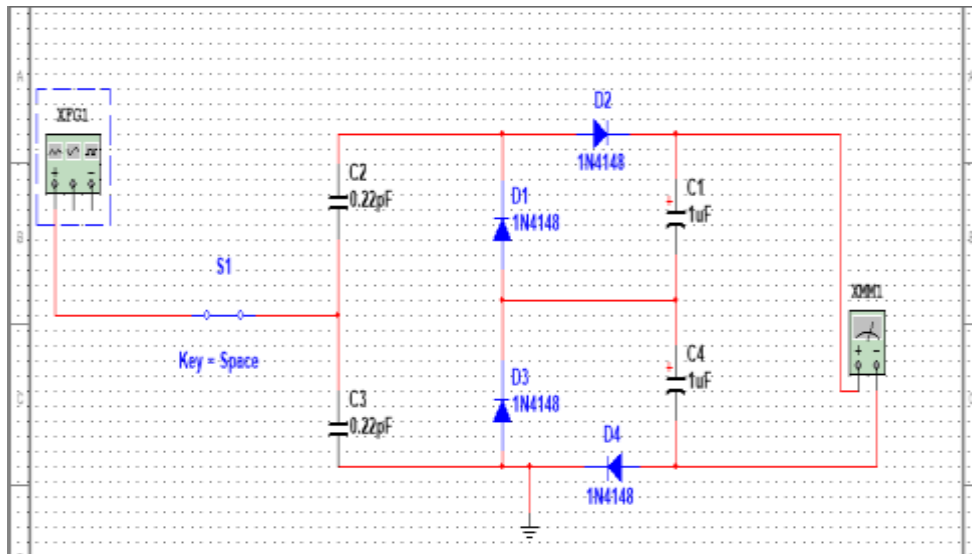

Figure 5: Circuit diagram

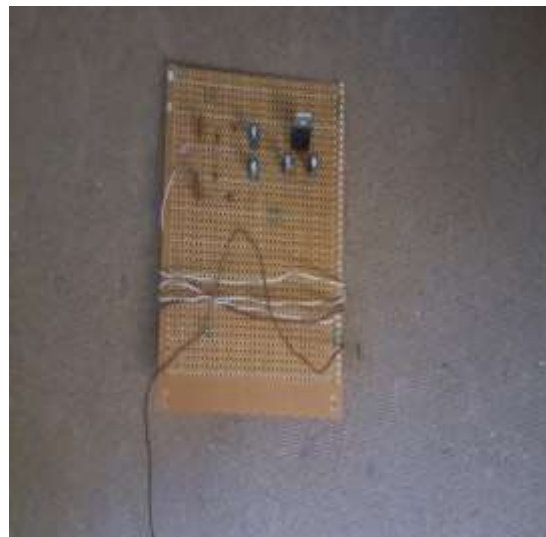

Figure 6 the circuit

### 5.0 Summary of results

As stated above, from the analysis software output most of the individuals requires some changes regarding to phone charging systems of which the idea of this project was to offer the solution to the stated problem that faces the community. Also, the output was 2.8V from the prototype design of which does not satisfy the charging of the mobile phone due to availability of the shortky diodes of low resistance as stated.

## 6.0 CONCLUSION AND RECOMMENDATION

### 6.1. Conclusion

Multi-band rectifiers allow wider application Reactive networks capable of minimizing rectifier efficiency sensitivity to load variation High PAPR leads to higher efficiency Spatial power combining for WPT transmitter. Also, the use of very low resistance diodes for rectification purpose helps to have fine final output of the project.

### 6.2. Recommendation

From the simulation and analysis of the project prototype the output dc satisfy for the charging of a mobile phone but the issue is the availability of the germanium diodes which are of very low resistance to support rectification of small dc obtained from the RF, So anybody need to proceed or modify the project need to find the germanium diode which will be able to rectify dc up to 5V that could satisfy for charging mobile phones. Also, there is a room for someone to develop this to a working phone charger which can charge the phone as per required criteria.

## REFERENCES

[1] Harrist, D. W., 2004. WIRELESS BATTERY CHARGING SYSTEM USING RADIO FREQUENCY ENERGY HARVESTING, s.l.: University ofPittsburgh.

[2] Carroll, A., n.d. An Analysis of Power Consumption in a Smartphone, s.l.: NICTA, University of New South Wales and Open Kernel Labs

[3] Anon., 1996. <http://examples.yourdictionary.com>. [Online]  
Available at: <http://examples.yourdictionary.com/law-of-conservation-of-energy-examples.html>  
[Accessed 10 February 2018].

[4] Harrist, D. W., 2004. WIRELESS BATTERY CHARGING SYSTEM USING RADIO FREQUENCY ENERGY HARVESTING, s.l.: University of Pittsburgh.

[5] Rewaskar, P. A., 2014. Computer Science And Engg.. Computer Science and mobile computing, III(4), pp. 427-432.

[6] Sayyad, A. J. & Sarvade, N. P., 2014. Wireless Power Transmission for Charging Mobiles. International Journal of Engineering Trends and Technology (IJETT), 12(June 2014), p. 331.

[7] Anon., 1996. <http://examples.yourdictionary.com>. [Online]  
Available at: <http://examples.yourdictionary.com/law-of-conservation-of-energy-examples.html>  
[Accessed 10 February 2018].