

Optimization of Electricity Supply to Onuiyi-Nsukka using Heuristic Technique for Shunt Capacitor Integration

Ohanu, Chibuike P.¹ Idoniboyeobu, Dikio C.² Braide, Sepiribo L.³

Research Scholar ^{1,3}, Professor ²

Department of Electrical Engineering

Rivers State University

Port Harcourt, Rivers State

Nigeria

ABSTRACT

This research work has been done in a distribution network (33/11KV) which is the most essential part in electricity supply chain. The Nigeria electricity distribution companies are saddled with the responsibility of providing optimal and sustainable electricity supply to consumers while maintaining the required voltage profile at minimal power losses. They are being confronted with dearth of electricity supply to match the much needed energy demand. This research presents the application of heuristic technique to determine the optimal capacitor location and size on a distribution network for an improved voltage profile, power loss reduction and increased energy savings. Analysis and investigation were performed using Onuiyi-Nsukka distribution network as case study. The critical voltage buses on the feeder are improved with the placement of shunt capacitors with the aim of achieving a voltage profile within the statutory limit of $1.0 \pm 0.05(0.95 - 1.05)p.u.$ The effects were noticed to be much in Bus (19) where voltage is 0.7186 p.u. which is about 24.4% deviation from the normal, bus (26) which is 0.786 p.u having 17.3% variation from the statutory limit and others. These results denote voltage deviations which causes damage to the system, and may lead to a possible system collapse if not optimized. The application of PSAT requested the use of heuristic technique with the integration of sized shunt capacitors. This reduced the network real power loss from 0.27MW to 0.12MW and the reactive power loss from 0.76Mvar to 0.13Mvar. The distribution network achieved an improved power quality. With this, electricity supply becomes reliable and sustainable for the electricity users.

Key Words: Power Flow, Distribution Losses, Loss Reduction, MATLAB, PSAT.

1. INTRODUCTION

The distribution system is the outermost part of the electricity supply chain, and as such the most exposed to the critical points of its users. It is that part of the power system which distributes power to the consumer for utilization. The Nigeria electricity sector has been saddled with the responsibility of sustaining a stable power supply. For past decades, a huge section of Nigerians has been experiencing the debilitating effects of shortage, epileptic, unstable and unreliable electricity supply and increased power breakdown of power infrastructure due to high power losses and low bus voltages in the power system [1]. It has been shown that excessive power losses and low bus voltage hinders the operation of the power system in Nigeria, and has contributed immensely to the incessant power failures, instability and unreliability of the Nigerian electric system. Optimization means finding an alternative way with the most cost-effective or highest achievable performance under the given limited resources, by maximizing desired ones and minimizing undesired ones. Optimization of electricity supply means to optimize the electrical energy consumption using efficient technologies with cost-effective way in a distribution system.

II. BACKGROUND OF STUDY

Electricity supply is delivered to consumers in three stages. This includes electrical power generation, transmission, and distribution. The consumers of electricity can be categories into residential, commercial and industrial areas [2]. The Federal

Government of Nigeria in an attempt to reform the power sector privatized the Distribution Companies (Discos) through the national council on privatization and the bureau for public enterprise in 2015[3]. This reformation is to enhance power quality and overall efficiency. The transformation in the distribution sector has resulted in the creation of eleven (11) distribution companies in the country. These include Ibadan, Kaduna, Port Harcourt, Jos, Benin, Eko, Ikeja, Kano, Yola, Abuja, and Enugu Companies. The development of any nation depends on the reliability and sustainability of its power sector [4]. There is an urgent need for sustainable electricity supply to the consumers for the socio-economic growth of the nation. These needs are hindered by the presences of losses in the power network, most especially in the distribution network which is the bulk source of electricity to the consumers. The minimization of losses in the distribution system is of great importance to electricity consumers. Since distribution network losses cost utility companies a huge amount of money, reduction of life expectancy of equipment, in attempts to reduce electricity cost, together with improving the efficiency of distribution systems, have led us to optimize the electricity supply to Onuiyi-Nsukka by dealing with the problem of power loss minimization.

In this paper, we optimized electricity supply to the 3-phase, 50Hz, 11kV Onuiyi-Nsukka distribution system, achieving efficiency and financial benefits which will result from lower maximum demand charges by the Enugu Electricity Distribution Company (EEDC) through power loss reduction while maintaining other parameters inside certain limits. The objective of this paper is to create awareness for the public targeting the government and organized the private sector on the need to solve the major challenges facing the Nigerian energy sector on electricity delivery to Nigerian consumers [1]. We achieved this by conducting the load flow studies on the 11kV Onuiyi-Nsukka distribution system, determine the power loss in the system and minimized the losses through optimal integration of shunt capacitor banks at the sensitive nodes(buses).

II. LITERATURE REVIEW

The literature review presented in this paper has two main purposes: firstly, it provides evidence of the knowledge gap that justifies the need for this work; and secondly, it also provides support for the methodology used in the study and is a source of information for comparison and reference.

A. Overview of The Nigerian Distribution Network

The voltage rates on the Nigeria distribution systems are classified into two: High voltage (33kV) and Low Voltage (11kV) values respectively. The 33kV side is taken as the primary side while the 11kV is the secondary side in a distribution station as discussed in [8]. The 11kV side of distribution network branches further into other 11kV feeders that will eventually terminate in the location where they are required to feed the residential consumers. If the manufacturing or production industries are to be fed from the distribution networks, the connection is from 33kV side before stepping the voltage down to 11kV [5]. In recent times, research has shown that using these machines and some of the residential loads results in a reduction in power quality, high losses and generates harmonics, voltage swells and flickering [7]. In the reviewed literature, their works showed that such devices that cause these reductions to include arcing devices, induction motor starting, Information and Communication Technology (ICT) equipment/facilities, electromagnetic radiations and cables, embedded generation, etc.

The typical Nigeria distribution network has the following characteristics as the time of carrying out this research and they include:

1. Consistent overloading of the distribution networks (distribution lines and transformers).
2. Prolonged abandonment of the distribution network and lack of upgrade.

B. Power Loss on Distribution Networks

Distribution network losses occur through two major sources. These are the transformer and distribution line losses. Power lines that connect substation to the loads are one of the major sources of losses in the distribution system. All the real power losses in distribution system are due to copper losses. Since the power losses on distribution system are considered to be entirely due to copper losses, it can be calculated using equation 1.

$$P_L = I^2 R \quad (1)$$

From equation (1), it shows that as the power that is transmitted along with the line increases, the current flow in the line becomes huge as shown in [9]. Transformer losses are the combination of both copper and core losses. Core losses consist of eddy current and hysteresis losses. The losses occur in the form of heat produced by both primary and secondary current windings of the transformer. The core losses in a transformer is usually larger in magnitude than the copper loss. Transformer core losses have been modelled in various ways, usually as resistance with the transformer's magnetizing reactance. Many researchers evaluated these losses and proffer several means of reducing losses on distribution networks.

C. Optimization of the Electrical Power Consumption for the Domestic Consumers

The optimization of electrical power consumption for domestic consumers was studied in [6]. Their study analyzed the development in the power sector of Bangladesh since inception using cutting edge technology. They found out from their analysis that the supply of resources in their country is always limited to meet the demand for their fast-growing population. Their work considers only the introduction of the most energy-efficient household appliances for homes but didn't consider the process of power flow in the distribution network that led to an improved power supply to consumers. The proposed use of Dynamic Voltage Restorer (DVR) which is one of the best suitable custom power devices for these types of power quality issues were studied in [10]. DVR makes the load voltage at the required magnitude and phase by compensating the voltage sag/swell and voltage unbalance at the point of common coupling (PCC). The basic configuration of DVR is shown in Figure.1.1.

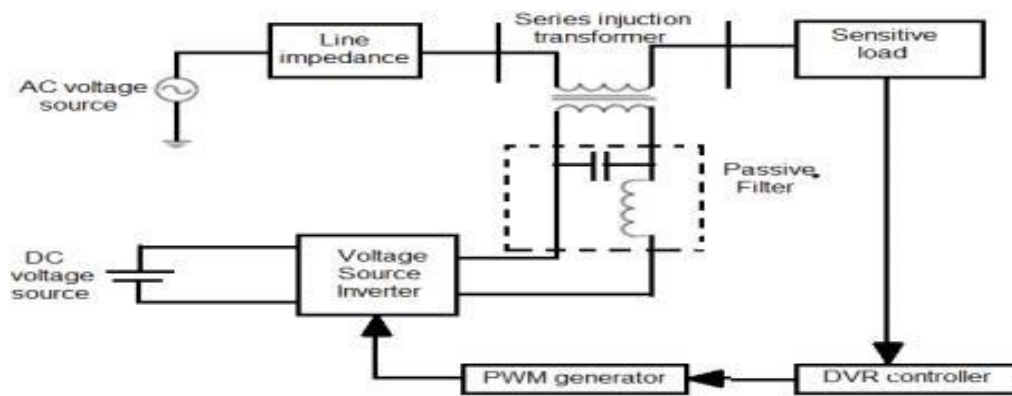

Figure 1.1. The basic configuration of DVR

The work only described the capability of the DVR to eliminate the power quality problems in a distribution network. The effects of loads on substations for the power quality was not taken into consideration. In this paper, we applied the heuristic technique to optimally integrate shunt capacitor banks at the buses where the voltage magnitude falls below or above the normal voltage range of $\pm 5\%$ p.u.

III. MATERIALS AND METHODS

The existing state of the power distribution network particularly that of our study area is considered for analysis and validation. There is a need to improve the distribution network for reliability and sustainability of electricity supply to prevent epileptic and power outages due to constant overloading of substations beyond its rated capacities. The losses on the power lines are the main basis for the selection of Newton-Raphson's power flow technique and heuristic technique for optimal shunt capacitors integration at critical buses to achieve minimal losses on the distribution network. The Power System Analysis Toolbox(PSAT)software embedded in MATLAB is used for modelling and analysis of the distribution network of our study case as shown in Figure 1.2.

A. Analysis Done on Onuiyi-Nsukka 11kV Distribution Network using Collected Data

We analyzed the 11kV Onuiyi-Nsukka feeder using the single line diagram in Figure 1.2 to determine the voltage profile, voltage phase angle, active and reactive power losses. Bus voltage magnitudes below the permissible limits ($V = 1.0 \pm 5\% p.u$) are not normal, hence the need for the improvement.

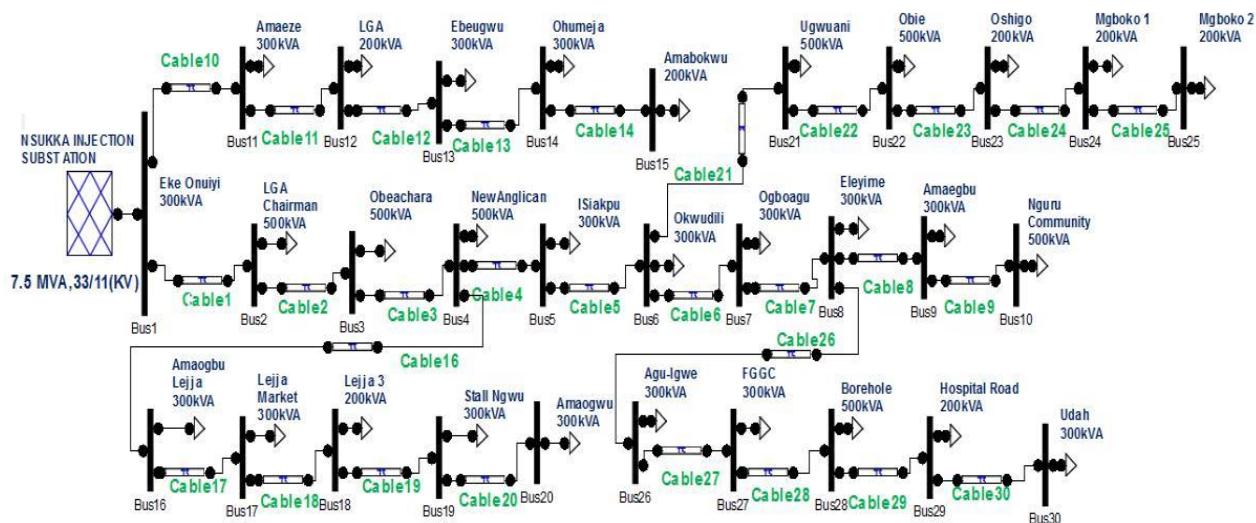

Figure 1.2: Single-line diagram of 30 bus Onuiyi-Nsukka distribution System with lateral branches showing the location of each load point.

The feeder data which includes both the bus and line data were collected from the Enugu Electricity Distribution Company for analysis. All calculations have been carried out in per unit system with the three-phase complex power base $S_B = 100MVA$ and base voltage $V_B = 11KV$. The feeder having total installed power of $7.5MVA$ with an average power factor of 0.85.

B. Heuristic Technique Algorithm

The flow chart in Figure 1.3 is the procedural method applied to Figure 1.2 in MATLAB/ Simulink environment to achieve the desired load flow report on the distribution network.

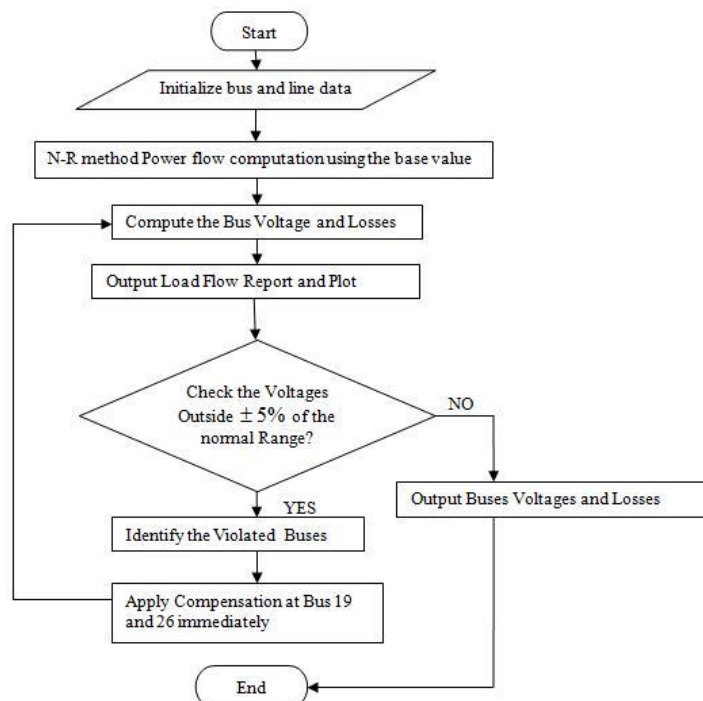

Figure 1.3: Flow chart to obtain bus voltages and losses using Heuristic Technique.

The procedure for the proposed technique is as follows:

- Step 1: initialize the bus and line data by computing them into the MATLAB model of the network.
- Step 2: perform power flow for the base case using Newton Raphson's (NR) technique.
- Step 3: compute all the bus voltage amplitudes and losses. Print the load flow report and plot the graphs.
- Step 4: select the critically violated bus (bus with the minimum p.u. voltage amplitude) in the network for reactive power compensation through shunt capacitor placement.
- Step 5: place a sized shunt capacitor bank at the critically violated bus to improve the power quality.
- Step 6: perform power flow again to ensure that voltage magnitude for all buses are within the voltage acceptable limit. If some buses are marginally violated, repeat step 5 by resizing or replacing a suitable sized shunt capacitor at the bus with minimum p.u voltage amplitude until all the bus are within the acceptable limits.
- Step 5: finally, place the suitable sized shunt capacitor at the appropriate location for reactive power compensation to achieve improved voltage profile and minimal power loss in the network.

C. Capacitor Sizing and Integration into the distribution network

The following information is required for capacitor sizing to determine the exact shunt capacitor size that will compensate for the losses by injecting reactive power into the network. They include:

- i. Installed transformer capacity at various load points
- ii. Existing power factor
- iii. The desired power factor for correction
- iv. Total active power on the load (kW)
- v. Application of the data to the governing equation for reactive power compensation as stated in equation (2).

$$Q_c = \frac{P}{pf_1} \times \sin \phi_1 - \frac{P}{pf_2} \times \sin \phi_2 \tag{2}$$

where;

Q_c = Reactive power factor correction (kVAr).

P = The total load active power (KW).

pf_1 = Existing power factor of the load.

pf_2 = Desired power factor to be used for correction.

$$\phi_1 = \cos^{-1}(pf_1) \tag{3}$$

$$\phi_2 = \cos^{-1}(pf_2) \tag{4}$$

$$Q_{CB} = \frac{P}{pf_1} \sin(\cos^{-1}(pf_1)) - \frac{P}{pf_2} \sin(\cos^{-1}(pf_2)) \tag{5}$$

D. Capacitor Sizing and Integration at Stall Ngwu and Agu-Igwe Sub-station (Buses 19 and 26)

- i. Installed transformer capacity = 300 kVA
- ii. Existing power factor $pf_1 = 0.77$
- iii. Desired power factor for correction $pf_2 = 0.95$
- iv. Total active power on the load (KW) = 2535 kW

$$\phi_1 = \cos^{-1}(0.77) = 39.65^\circ, \quad \phi_2 = \cos^{-1}(0.95) = 18.19^\circ$$

$$Q_{CB} = \left(\frac{2535}{0.77} \sin(39.65) - \frac{2535}{0.95} \sin(18.19) \right) = 1200 \text{ K var}$$

This is the required size of the capacitor needed to improve the voltage profile of the entire distribution network when placed at Stall Ngwu and Agu-Igwe sub-stations (Buses 19 and 26).

IV. RESULTS AND DISCUSSIONS

The results from the power flow analysis on the existing state and improved state of the distribution network are presented in Figures 1.4 and 1.5. The voltage profiles and power losses at the substations for both existing and improved state are presented in Figures 1.6 and 1.7.

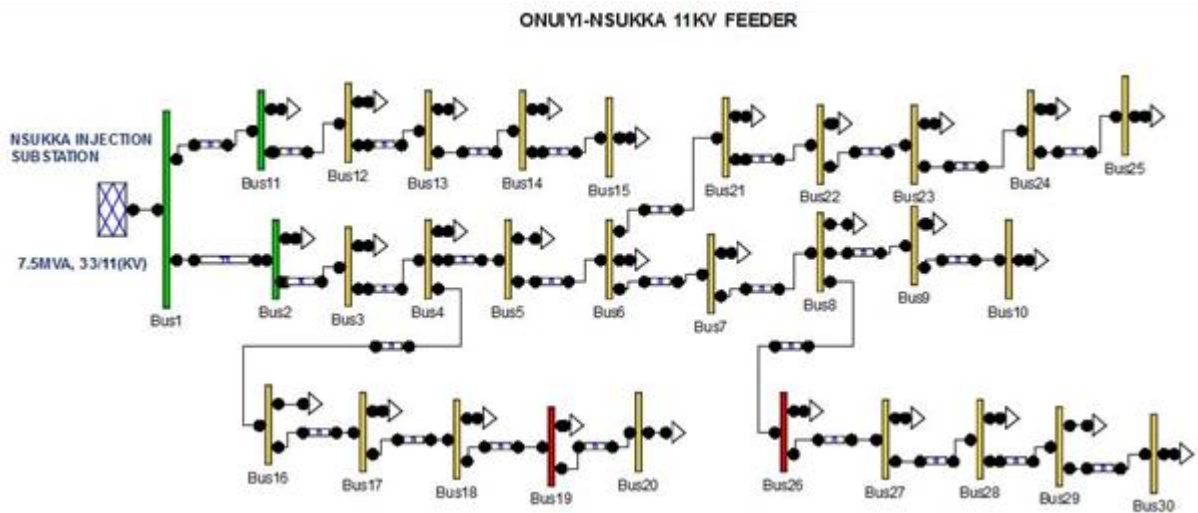

Figure 1.4: Single line diagram of the 11kV Onuiyi-Nsukka distribution network without shunt capacitor banks integration

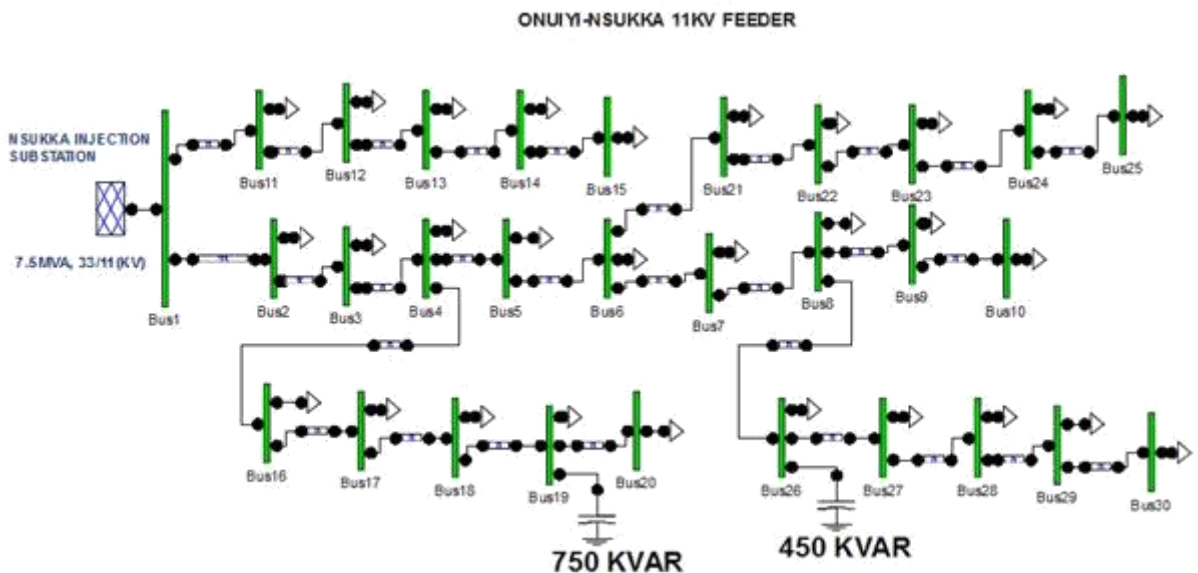

Figure 1.5: Single line diagram of the 11kV Onuiyi-Nsukka distribution network with shunt capacitor banks integration

Table1.1. presents the voltage magnitudes of the 30 bus Onuiyi-Nsukka distribution network without capacitor bank integration and with the integration of capacitor bank at bus 19 and 26. The voltage profile for comparison between the networks existing and improved state is shown in Figure1.6. This shows an overall improvement of the distribution

network with capacitor bank integration on buses 19 and 26. This effect improved the voltage profile of the network without any voltage violation on the buses.

Table 1.1: Voltage magnitude of the existing state and improved state of the network

Bus No.	Bus Name	Voltage magnitudes [p.u]	
		Without compensation	With compensation
Bus1	Eke Onuiyi	1.050000	1.050000
Bus2	LGA Chairman	1.015591	1.049559
Bus3	Obeachara	0.910264	1.049937
Bus4	New Anglican	0.904733	1.009473
Bus5	Isiakpu	0.904226	1.039942
Bus6	Okwudili	0.906255	1.059255
Bus7	Ogboagu	0.901199	1.059212
Bus8	Eleyime	0.903145	1.031454
Bus9	Amaegbu	0.858856	1.005886
Bus10	Nguru Community	0.901657	1.029866
Bus11	Ameaze	1.049736	1.019736
Bus12	LGA	0.902193	1.029919
Bus13	Ebugwu	0.900271	1.019971
Bus14	Ohumeja	0.853483	1.053483
Bus15	Amabokwu	0.880865	1.019831
Bus16	Amaogbu Lejja	0.894048	1.041405
Bus17	Lejja Market	0.880029	1.028029
Bus18	Lejja 3	0.897328	1.019973
Bus19	Stall Ngwu	0.718694	1.051869
Bus20	Amaogwo	0.899647	1.029996
Bus21	Ugwuani	0.885487	1.058855
Bus22	Obie	0.876099	1.019961
Bus23	Oshigo	0.943453	1.043453
Bus 24	Mgboko 1	0.871407	1.048714
Bus25	Mgboko 2	0.869935	1.004987
Bus26	Agu-Igwe	1.186993	1.005087

Bus27	FGGC	0.898294	1.028983
Bus28	BoreHole	0.873254	1.028325
Bus29	Hospital Road	0.896271	1.029963
Bus30	Udah	0.864949	1.048649

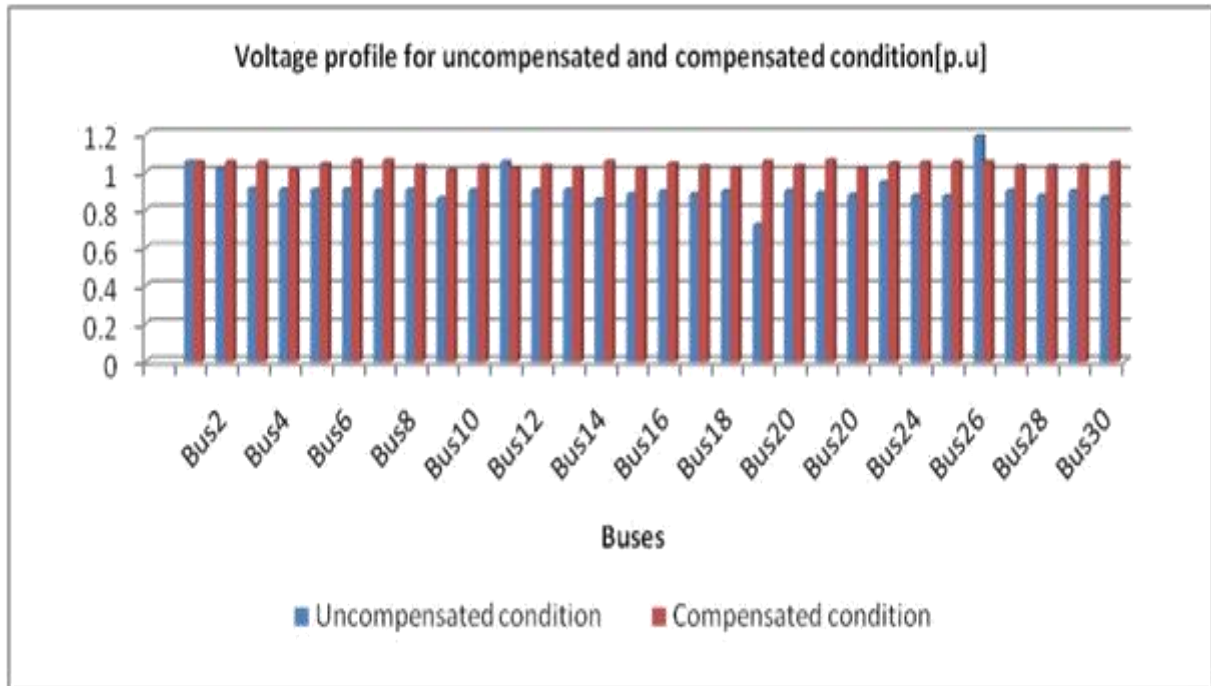

Figure 1.6: Voltage profile of the network for the uncompensated and compensated state.

Table 1.2. presents the detailed results of the reactive power loss flow in the lines emanating from the buses in the distribution network. The comparison of the uncompensated and compensated reactive bus losses was shown in Figure 1.7. From the graph, it is shown that there is a great reduction of power losses along the lines with the network compensation. This reduced the total amount of loss on the lines from $(0.00276 + j0.00763) p.u$ to $(0.0023 + j0.0035) p.u$. Meanwhile, in Figure 1.7, we recorded a percentage loss reduction of 66.7% and 81.6% for both active and reactive power after the integration of shunt capacitor banks on the distribution network.

Table 1.2 Reactive power flow in the network

From Bus	To Bus	Uncompensated[Mvar]	Compensated[Mvar]
Nsukka S/S	Eke Onuiyi	0.006652	-0.02665
Eke Onuiyi	LGA Chairman	0.032722	0.000303
LGA Chairman	Obeachara	0.0887	0.003221
Obeachara	New Anglican	0.030105	0.000301
New Anglican	Isiakpu	0.013662	0.000137
Isiakpu	Okwudili	0.222682	2.23E-05
Okwudili	Ogboagu	0.045185	0.004519
Ogboagu	Eleyime	0.096393	-0.00964
Eleyime	Amaegbu	0.052336	0.000523
Amaegbu	Nguru Community	0.023935	-0.00024

Nguru Community	Ameaze	0.030713	-0.00307
Ameaze	LGA	0.097003	-0.00970
LGA	Ebugwu	0.011237	-0.00011
Ebugwu	Ohumeja	0.025771	0.000258
Ohumeja	Amabokwu	0.011695	0.000117
Amabokwu	Amaogbu Lejja	0.001906	-1.9E-05
Amaogbu Lejja	Lejja Market	0.003868	-0.00039
Lejja Market	Lejja 3	0.000735	0.000735
Lejja 3	Stall Ngwu	0.004246	-0.00042
Stall Ngwu	Amaogwo	0.219267	0.001927
Amaogwo	Ugwuani	0.031404	3.14E-05
Ugwuani	Obie	0.063723	-6.4E-05
Obie	Oshigo	0.050922	-0.00509
Oshigo	Mgboko 1	0.052127	-0.05213
Mgboko 1	Mgboko 2	0.014083	-0.01408

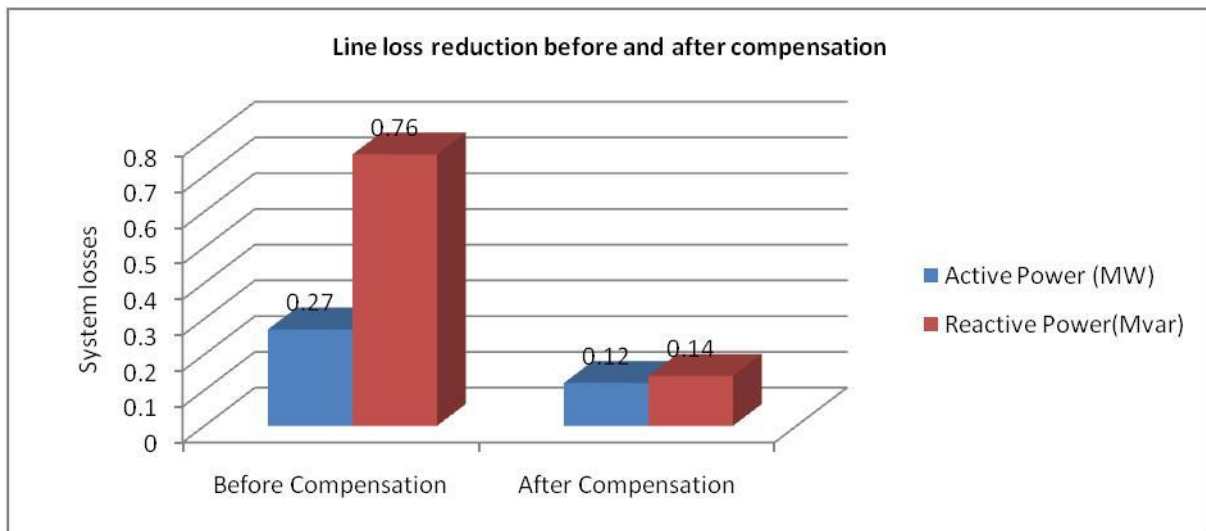

Figure1.7: Active and Reactive power loss before and after integration of shunt capacitors at buses 19 and 26

V. CONCLUSION

The distribution networks are normally designed to operate at an optimal capacity and voltage level suitable for power system operating conditions. The ability of this distribution network to reduce losses during operation will improve the reliability and sustainability of electricity supply and this will provide adequate revenue for expansion and modernization soon. In recent times, many distribution networks are challenged with the devastating effect of power loss and Engineers have to put in place technical measures to reduce these losses. This project was done on 3-phase 11KV, 50 Hz Onuiyi-Nsukka distribution network, therefore presents a special technique for electricity supply optimization to Onuiyi-Nsukka by reducing the power losses due to the flow of reactive power in the distribution network. This heuristic technique adopts optimal capacitor integration at a few locations in the network "critical buses" to achieve a significant loss reduction.

ACKNOWLEDGEMENT

The authors of this paper wish to express their profound gratitude to the Department of Electrical Engineering, Faculty of Engineering, Rivers State University, Port Harcourt, Nigeria for providing the necessary facilities. The author Ohanu Chibuike Peter would like to thank the African Center of Excellence for Sustainable Power and Energy Development (ACE-SPED), University of Nigeria, Nsukka and Dr. Ohanu Ifeanyi B. for their support and attention.

REFERENCES

- [1] J. O. Adepitan and E. O. Oladiran, "Analysis of dependence of power outages on lighting Event with Ijebu province Nigeria.," *Journal of Environmental and Earth Science*, pp. 482-492., 2016.
- [2] M. C. Anumaka, "Analysis of technical losses in electrical power system (Nigerian 330kV network as a case study)," *International Journal of Research and Reviews in Applied Sciences (IJRRAS)*, vol. 12, no. 2, pp. 320-327, 2012.
- [3] "Federal Republic of Nigeria National Power Sector Training Policy on Power," Abuja, 2015.
- [4] P. E. Okoroma , "Improved Electric Power Distribution Network in Nigeria Using Voltage drop/Voltage Regulation Method," *American Journal of Engineering Research(AJER)*, vol. 8, no. 4, pp. 310-318, 2019.
- [5] S. O. Onohaebi and E. Omorogiuwa , "Prospects of Custom Power Devices in Improving Reliability of Distribution Networks in Nigeria," *International Journal of Research in Engineering & Applied Sciences*, vol. 5, no. 5, p. 2278 – 4209, 2009
- [6] J. W. Smith et al., "Smart inverter volt/var control functions for high penetration of PV on distribution systems," in *IEEE/PES Conference and Exposition (PSCE)*, Phoenix, AZ., 2011
- [7] U. C. Ogbuefi , B. O. Anyaka, M. J. Mbunwe and T. C. Madueme, "Nigerian Electric Power Grid Compensation Effect on the Interconnected," in *Proceedings of the World Congress on Engineering and Computer Science*, WCECS, San Francisco, USA, 2017
- [8] J. N. Swanky, "A Review on Power distribution," *International Journal of Research in Engineering & Applied Sciences (IJREAS)*, vol. 2, no. 2, pp. 234-245, 2012.
- [9] A. Uzodife , "High power loss reduction in Enugu distribution system," in *NIEEE Conference on engineering developmen*, Enugu, Nigeria, 2013.
- [10] D. Zhu et al. , "Impact of dg placement on reliability and efficiency with time varying loads," *IEEE Trans. Power System*, vol. 21, pp. 419-427, 2006.